



 A BTR Metering Systems Company

Package Monitor Sets

Model 243-DOT

“Duplex Overpressure Tandem”

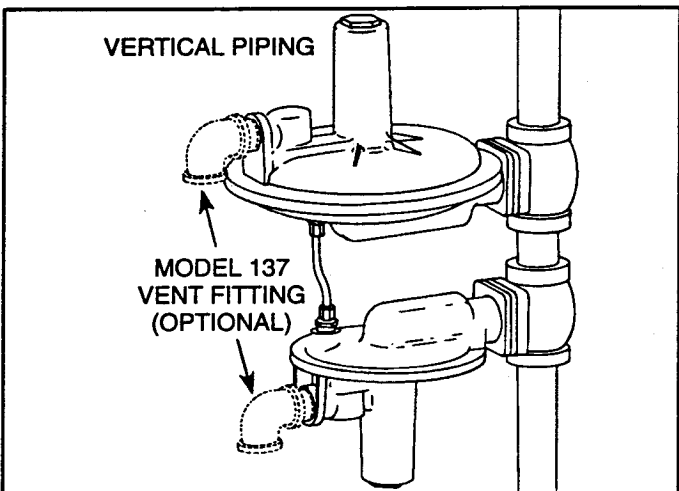
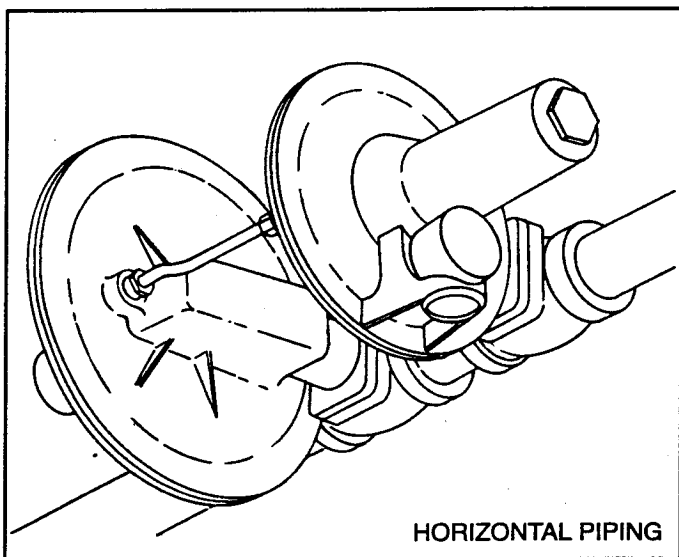
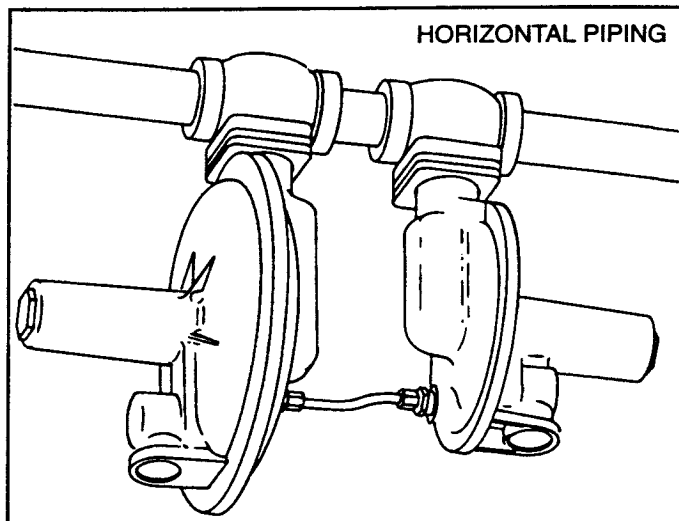

Pipe Sizes:

1 $\frac{1}{4}$ ”, 1 $\frac{1}{2}$ ” and 2” Screwed NPT
2” Flanged ANSI 125

Outlet Pressures:

243-DOT-12 x 8	3 $\frac{1}{2}$ ” w.c. to 2 psi
243-DOT-12 x 12	3 $\frac{1}{2}$ ” w.c. to 2 psi
243-DOT-8 x 12	3 $\frac{1}{2}$ ” w.c. to 2 psi
243-DOT-8 x 8	3 $\frac{1}{2}$ ” w.c. to 4 psi
243-DOT-8HP x 8HP	3 psi to 10 psi

Inlet Pressures.....to 125 psi (see Table, Page 2)

The 243-DOT is a full-fledged monitor set – factory assembled, complete, ready to use.

It's all self-contained in a single package . . . compact, economical, easy to install.

Both regulators are standard Model 243's . . . 243-12, 243-8 or 243-8HP. An IRV is available in the downstream monitor.

No special valves, seats, orifices, stems, seals, O-rings, diaphragms, springs . . . all parts are standard 243 parts.

One regulator operates normally. The other is a monitor. If failure in the normally operating regulator causes outlet pressure to rise, the monitor takes over.

Upstream or downstream monitoring is optional. Simply specify when ordering whether the monitor should be the upstream or downstream regulator. If not specified, monitor upstream will be supplied.

Only two pipe connections, the inlet and outlet . . . it's just like installing any standard service regulator. There are no control lines to install. The downstream regulator has internal control. And the control line for the upstream regulator is a short piece of tough, strong, seamless steel tubing, factory installed.

Complete seat inspection is as easy as on any standard service regulator. Simply loosen both union connections and remove the diaphragm heads together for complete access to both valves and both orifices. Servicing either diaphragm assembly or changing either spring is the same as on any standard 243. For installation and servicing instructions see RM-1306-1.

A Monitor Indicator is available. It shows if the monitor is in operation, or if it was in operation at some previous time.

Vent fittings (Model 137) are available where piping is vertical and it is necessary to face the vents downward. See the vertical piping illustration, this page.

And, $\frac{1}{4}$ ” NPT taps are available on the inlet, and the intermediate pressure chambers.



Dimensions

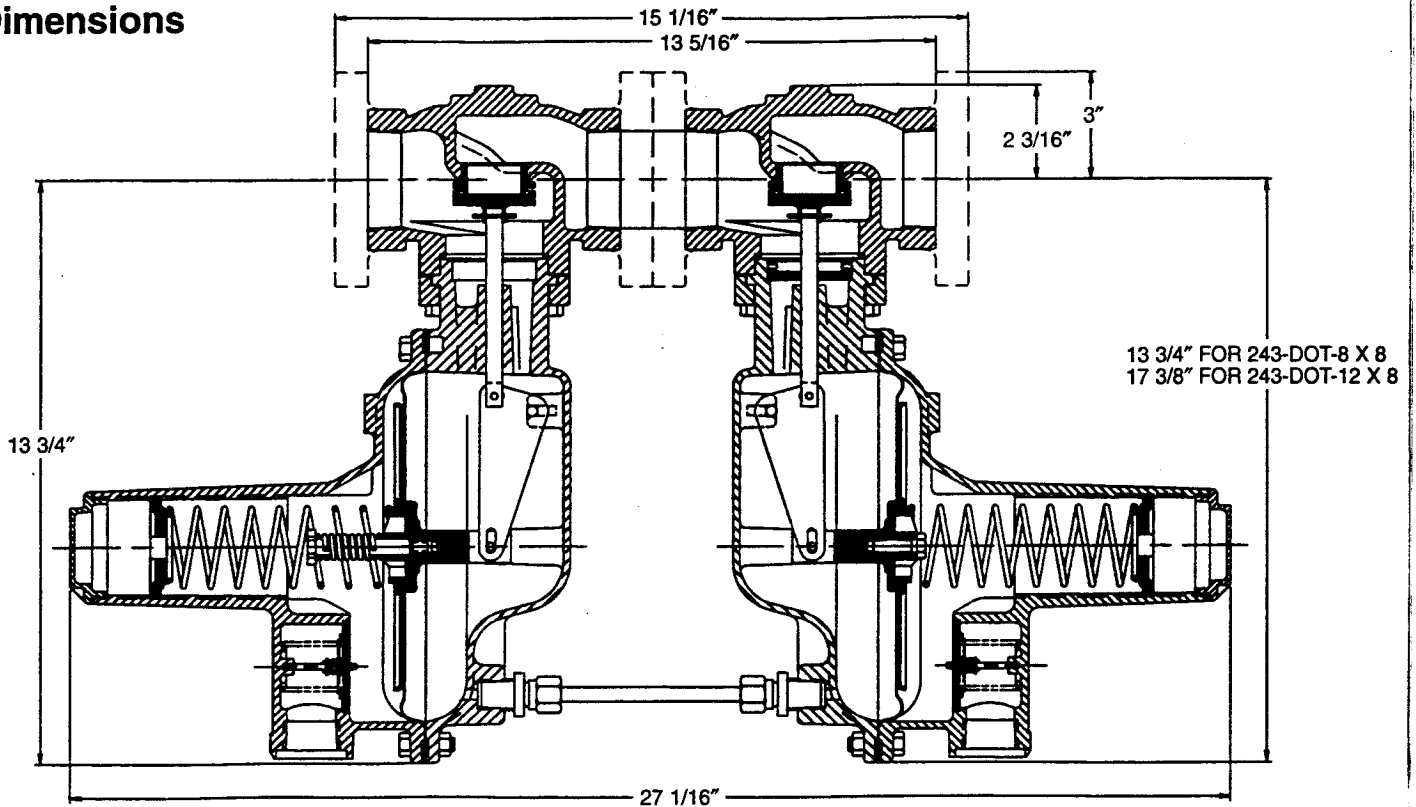

Model Numbers

Model Number	Monitor Location	243 Regulator Used	
		Upstream Regulator	Downstream Regulator
243-DOT-12x8	Downstream	243-12-1	243-8-1 or 243-8-2
	Upstream	243-8-1	243-8-1
243-DOT-8x8	Downstream	243-8-1	243-8-1 or 243-8-2
	Upstream	243-12-1	243-12-1
243-DOT-12x12	Downstream	243-12-1	243-12-1 243-12-2
	Upstream	243-8-1	243-12-1
243-DOT-8HPx8HP	Upstream or Downstream	243-8HP	243-8HP

(Refer to Bulletin R 1306 for complete descriptions of individual regulators.)
NOTE: The term standard refers to non-IRV configurations.

Spring Ranges

Spring Color	243-12-1	243-8-1 and 243-8-2
Red-Black	—	3 1/2" to 6 1/2" w.c.
Blue-Black	—	5" to 8 1/2" w.c.
Green-Black	—	6" to 14" w.c.
Red	3 1/2" to 6 1/2" w.c.	—
Blue	5" to 8 1/2" w.c.	—
Green	6" to 14" w.c.	12" to 28" w.c.
Orange-Black	10" to 18" w.c.	—
Orange	12" to 28" w.c.	1 to 2 psi
Black	1 to 2 psi	2 to 4 1/2 psi
Cadmium	1 1/2 to 3 psi	3 to 6 1/2 psi*
Cadmium/White	—	6 to 10 psi*

*243-8HP

Maximum Inlet Pressure

Orifice Size	1 1/4"	1"	3/4"	1/2"	1/4"	1/8"
Maximum Inlet Pressure	15 psi	25 psi	40 psi	80 psi	100 psi	125 psi

Where the two regulators have different size orifices, Maximum Inlet Pressure is established by the larger orifice.

Internal Relief Valve

If an IRV (Internal Relief Valve) is used, it should only be used in the downstream monitor (as shown in the Model Numbers table). The standard IRV begins to relieve at approximately 9" w.c. above regulator set-point. A special spring is available for the 243-8-2 to relieve at approximately 20" w.c. above regulator set-point.

For a description and drawing of the IRV, refer to the 243 bulletin, R 1306.

Because of its size, the IRV will only provide full capacity relief with the smaller orifices at low inlet pressures. Therefore, it is important to check IRV capacity. Use the performance curves in R 1306.

Probably the most useful function of the IRV is to warn that the monitor is not operating correctly.

The normally operating regulator could have an IRV. However, this would be special. Furthermore, note carefully that the IRV would most likely have a lower set-point than the monitor. Thus, the IRV would begin to relieve before the monitor comes into operation.

Note also that if an IRV is used in the upstream regulator, relief capacity is considerably reduced by the control line inter-connection between the diaphragm cases.

Monitor Set-Point

The set point of the normally operating regulator is the normal outlet pressure. The set-point of the monitor must, of course, be higher. In deciding how much higher, comply generally with standard gas industry practice. The following can be used as a guide:

1. At 7" w.c. normal set-point . . . monitor set-point should be 10" w.c. or higher.
2. At 18" w.c. normal . . . monitor should be 24" w.c. or higher.
3. At 1 psi normal . . . monitor should be 1¼ psi or higher.
4. At 2 psi normal . . . monitor should be 2½ psi or higher.
5. At 3 psi normal . . . monitor should be 3½ psi or higher.

Monitor set-point can be closer than the above values. However, be careful to avoid getting too close to normal set-point. If too close, the monitor could interfere with the normally operating regulator.

Periodic Inspection

Regulators are pressure control devices with numerous moving parts subject to wear that is dependent upon particular operating conditions. To assure continuous satisfactory operation, a periodic inspection schedule must be adhered to with the frequency of inspection determined by the severity of service and applicable laws and regulations.

Monitor Indicator*

While outlet pressure is normal, the monitor remains idle in a wide-open position. If a failure in the normally operating regulator causes outlet pressure to rise, the monitor takes over. It goes into operation when outlet pressure reaches its set-point, and provides protection by preventing any further rise in pressure.

The Monitor Indicator shows whether the monitor is idle (wide-open) or operating. It also shows if it was previously in operation.

Referring to the drawing (below), as long as the floating indicator remains below the line, the monitor has remained idle. The floating indicator above the line with the positive indicator below means that although the monitor is presently idle, it was in operation at some prior time.

Whenever the floating indicator is found above the line, it must be reset. This is easily done by removing the cover-plug at the top of the transparent tube and pushing the indicator down.

The Monitor Indicator is a handy and dependable device at any flow up to the capacity table value. However, it should not be used if flow exceeds this value.

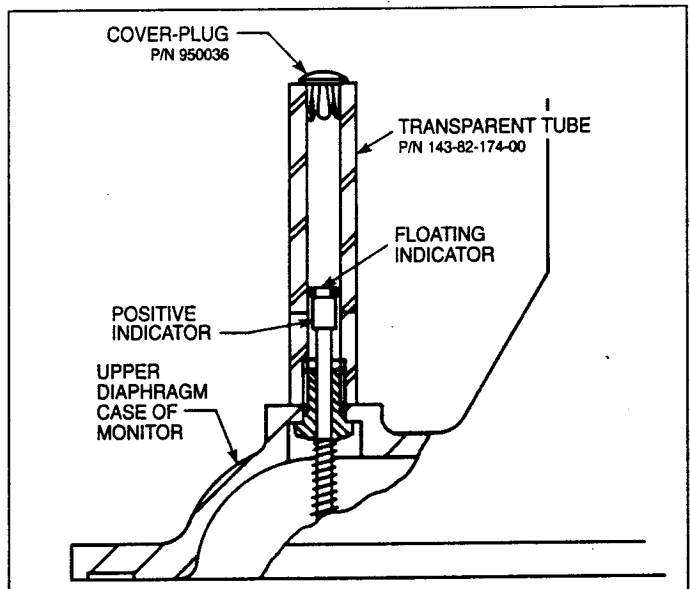

*Monitor Indicator – Not recommended for inside applications because of leak potential.

CAPACITY in scfh of natural gas (0.6 Specific Gravity, 14.65 psia, 60°F)

OUTLET PRESSURE	2" Model 243-DOT-12 x 8 or 8 x 12				INLET PRESSURE psi	1 1/2" Model 243-DOT-12 x 8 or 8 x 12				OUTLET PRESSURE
	1/4" - 30° orifice	1" - 30° orifice	3/4" - 30° orifice	3/4" - 10° orifice		1/4" - 30° orifice	1" - 30° orifice	3/4" - 10° orifice	1/2" - 10° orifice	
7" w.c.	4200	3900	2800	2300	2	2700	2300	1800	1300	7" w.c.
1" w.c.	7700	7700	5600	4200	5	4000	3600	3000	2300	1" w.c.
Droop		10000	8400	5900	10		5300	4200	3800	Droop
Blue Spring		10500	10500	7000	15		6400	4900	4600	Blue Spring
			14000	8100	25			5900	5500	
				9500	40			7000	6700	
					60				7400	
18" w.c.	3000	2400	1900	1700	2	2100	2000	1600	1100	18" w.c.
3" w.c.	5600	5000	4000	3300	5	3900	3700	3000	1800	3" w.c.
Droop		8400	7400	5300	10		5400	4200	3000	Droop
Orange Spring		10200	10500	6700	15		6500	5200	4100	Orange Spring
			14000	8100	25			6400	5500	
				9500	40			7700	6700	
					60				7700	
1 psi	2400	2100	1400	1300	2	2000	1700	1100	900	1 psi
0.2 psi	4600	4100	3000	2700	5	3900	3600	2600	1700	0.2 psi
Droop	7700	7000	5300	4600	10	5600	5300	4000	2800	Droop
Black Spring		8400	6500	5800	15		6400	5000	3700	Black Spring
			11600	7700	25			6500	5100	
				9800	40			7700	6500	
					60				7700	
2 psi	5800	5200	3700	3400	5	4200	3700	2900	1900	2 psi
0.6 psi	8800	7900	6100	5500	10	7000	6500	5000	3300	0.6 psi
Droop		10200	8100	7000	15		8400	6200	4400	Droop
Black Spring			11600	9500	25			7700	6000	Black Spring
				11600	40			9500	7700	
					60				9500	

NOTE: The performance data is based on normal testing at 70°F flowing temperature. Changes in performance can occur at extreme low flowing temperatures.

CAPACITY in scfh of natural gas (0.6 Specific Gravity, 14.65 psia, 60°F)

OUTLET PRESSURE	2" Model 243-DOT-8 x 8						INLET PRESSURE psi	1 1/2" Model 243-DOT-8 x 8						OUTLET PRESSURE
	1" - 30° orifice	3/4" - 30° orifice	1/2" - 10° orifice	1/2" - 10° orifice	3/4" - 10° orifice	1" - 10° orifice		1" - 30° orifice	3/4" - 10° orifice	1/2" - 10° orifice	1/2" - 10° orifice	3/4" - 10° orifice	207" - 10° orifice	
7" w.c.	1900		1300	1000	700	300	2	1900	1300	1000	700	300	250	7" w.c.
	3400		2500	1700	1100	600	5	3400	2500	1700	1100	600	350	
1" w.c.	4900		3800	2700	1800	900	10	4900	3800	2700	1800	900	650	1" w.c.
Droop			4900	3500	2500	1200	15		4900	3500	2500	1200	800	Droop
Blue-Black Spring				4600	3600	1700	25			4600	3600	1700	1100	Blue-Black Spring
					5000	2300	40				5000	2300	1500	
						3100	60					3100	2000	
18" w.c.	1700	1300	1200	900	700	350	2	1500	1200	900	630	300	250	18" w.c.
	3900	2600	2500	1600	1000	650	5	3200	2400	1400	950	600	400	
3" w.c.	6600	5900	4200	2600	1700	1000	10	4600	4000	2500	1700	900	600	3" w.c.
Droop	8400	8400	5700	3900	2700	1200	15	6200	5000	3500	2400	1200	700	Droop
Green Spring		12300	7000	5800	4000	1700	25		6400	5000	3600	1700	1100	Green Spring
				8100	5200	2400	40			6500	5000	2300	1500	
				9500	7000	3200	60			7700	6600	3100	2000	
1 psi	1700	1300	1200	840	600	300	2	1500	1200	900	600	300	400	1 psi
	2800	2400	2300	1600	900	650	5	2800	2300	1500	900	600	600	
0.2 psi	4900	4200	3800	2500	1600	1000	10	4600	3700	2200	1600	900	700	0.2 psi
Droop	7700	6300	4900	3200	2200	1200	15	5900	4600	3100	2100	1200	700	Droop
Orange Spring		10500	7000	5200	3400	1700	25		6000	4600	3100	1700	1100	Orange Spring
				7400	4900	2400	40			6000	4700	2300	1500	
				8800	6700	3200	60			7400	6300	3100	2000	
3 psi	3100	2400	2300	1700	1100	600	5	3100	2400	1700	1100	600	500	3 psi
	5300	4200	4100	2500	1700	900	10	5000	4100	2500	1700	900	700	
0.6 psi	7700	6300	5300	3400	2500	1200	15	6700	5300	3400	2400	1200	1100	0.6 psi
Droop		10500	7400	5600	3600	1700	25		7400	4600	3500	1700	1100	Droop
Black Spring				8000	4900	2400	40			6700	4900	2300	1500	Black Spring
				9800	6700	3200	60			8800	6500	3100	2000	

NOTE: The performance data is based on normal testing at 70°F flowing temperature. Changes in performance can occur at extreme low flowing temperatures.

CAPACITY in scfh of natural gas (0.6 Specific Gravity, 14.65 psia, 60°F)

OUTLET PRESSURE	2" Model 243-DOT-12 x 12						INLET PRESSURE psi	1 1/2" Model 243-DOT-12 x 12						OUTLET PRESSURE
	1" - 30° orifice	3/4" - 30° orifice	3/4" - 10° orifice	1/2" - 10° orifice	1/4" - 10° orifice	1/4" - 10° orifice		1" - 30° orifice	3/4" - 10° orifice	1/2" - 10° orifice	1/4" - 10° orifice	1/4" - 10° orifice		
7" w.c.	4200	2800	2200	1400	900	400	2	2300	1800	1300	900	420	7" w.c.	
	7700	5600	4200	2600	1500	700	5	3600	2900	2300	1500	700		
1" w.c.	9800	8400	5900	3900	2300	1000	10	5300	4200	3800	2200	1000	1" w.c.	
Droop	10500	10500	7000	5000	2800	1200	15	6400	4900	4600	2700	1200	Droop	
		14000	8000	6600	3700	1700	25		5900	5500	3600	1700		
Blue Spring			9400	8400	5200	2200	40		7000	6600	5000	2200	Blue Spring	
			9100	9100	7000	3100	60			7400	6500	3100		
18" w.c.	2400	1900	1700	1000	700	350	2	2000	1500	1100	700	350	18" w.c.	
	5000	3900	3300	2000	1300	660	5	3600	2900	1800	1300	670		
3" w.c.	8400	7300	5200	3400	2000	1000	10	5400	4200	3000	2000	1000	3" w.c.	
Droop	10100	10500	6600	4500	2700	1200	15	6500	5200	4100	2700	1200	Droop	
		14000	8000	6400	3700	1600	25		6400	5500	3600	1700		
Orange Spring			9400	8400	5200	2200	40		7700	6600	5000	2200	Orange Spring	
			9100	9100	7000	3100	60			7700	6500	3100		
1 psi	2100	1400	1300	800	700	350	2	1700	1100	840	600	350	1 psi	
	4100	2900	2700	1700	1100	700	5	3600	2600	1700	1100	670		
0.2 psi	7000	5300	4500	2900	2000	1000	10	5300	4000	2800	1900	1000	0.2 psi	
Droop	8400	6500	5800	3900	2700	1200	15	6400	5000	3700	2600	1200	Droop	
		12000	7700	5900	3700	1700	25		6500	5100	3600	1700		
Black Spring			9800	8700	5200	2400	40		7700	6500	5000	2200	Black Spring	
			9100	9100	7000	3100	60			7700	6500	3200		
3 psi	2100	1400	1300	1000	800	500	5	2100	1400	1000	770	350	3 psi	
	4900	3800	3500	2100	1400	800	10	4200	3500	1800	1400	700		
0.35 psi	7000	5600	4900	2800	2100	1100	15	5600	4900	2500	1800	1100	0.35 psi	
Droop		6900	6300	3900	3100	1400	25		5600	3400	3200	1300	Droop	
			14000	7300	5200	2400	40		8100	4600	4200	2500		
Cadmium Spring				10100	7300	3100	60			5600	5300	3200	Cadmium Spring	

NOTE: The performance data is based on normal testing at 70°F flowing temperature. Changes in performance can occur at extreme low flowing temperatures.

Maximum Emergency Pressures

The maximum pressure the inlet may be subjected to under abnormal conditions without causing damage to the regulators is:

243-DOT-12x8	Maximum Inlet Pressure+50 psi
243-DOT-8x8	Maximum Inlet Pressure+50 psi
243-DOT-12x12	Maximum Inlet Pressure+50 psi
243-DOT-8x12	Maximum Inlet Pressure+50 psi
243-DOT-8HPx8HP	Maximum Inlet Pressure+50 psi

(Take applicable Maximum Inlet Pressure from the table above.)

This rating applies throughout the body of the upstream regulator and into the inlet side of the downstream regulator.

The maximum pressure the outlet (outlet side of the downstream regulator) may be subjected to without causing damage to the internal parts of the regulators is:

243-DOT-12x8.....	set-point+3 psi
243-DOT-8x8.....	set-point+5 psi
243-DOT-12x12.....	set-point+3 psi
243-DOT-8x12.....	set-point+3 psi
243-DOT-8HPx8HP.....	set-point+5 psi

Set-point is defined as the outlet pressure a regulator is adjusted to deliver.

If any of the above pressure limits are exceeded, the regulators must be taken out of service and inspected. Damaged or otherwise unsatisfactory parts must be repaired or replaced.

The maximum pressure that can be safely contained by the diaphragm cases is:

243-DOT-12x8.....	15 psi
243-DOT-8x8.....	15 psi
243-DOT-12x12.....	15 psi
243-DOT-8x12.....	15 psi
243-DOT-8HPx8HP	25 psi

Safely contained means no leakage as well as no bursting.

Before using any of the above data, make sure this entire section is clearly understood.

NOTE: The use of an internal or external relief valve is recommended for installations subjected to no flow for extended periods of time, such as pilotless ignition systems. A travel stop stem is located in the 243-12-1 and 243-12-4 to provide overpressurization protection to internal components during lockup.

Materials of Construction

Bodies	Cast Iron
Diaphragm Cases	Die Case Aluminum Alloy
Diaphragms	Buna-N with Nylon Fabric Insert
Diaphragm Pans	Zinc Plated Steel
Diaphragm Couplings.....	Zinc Die Casting
Orifices	Brass
Valves.....	Buna-N Soft Seat in Aluminum Holder
Stems	Brass
Lever.....	Zinc Plated Steel
O-Rings and Tetra Seals	Buna-N
Adjustment Spring Buttons & Seal Caps	Zinc Die Casting
Connecting Pipe Nipple	Sch 80 Steel Pipe
Connecting Control Line...3/8" Seamless Stainless Steel Tubing	

Vent Positions

Specify vent positions as follows. In each figure you are looking at the regulator outlet.

If not specified, Position 1 will be furnished.

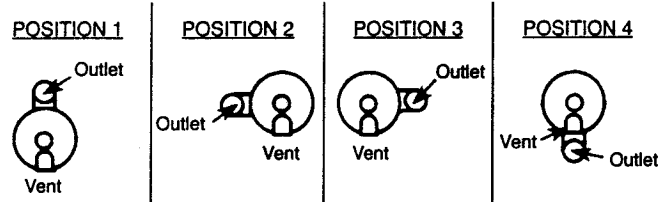

NOTE: For vertical piping, use the 1" Model 137 Vent Assembly to face vents downward.

How to Order

- Pipe Size 1/4", 1/2", or 2" screwed or 2" flanged.
- Model Numbers: 243-DOT-12x8
243-DOT-8x8
243-DOT-8x12
243-DOT-12x12
243-DOT-8HPx8HP
- Vent Position: 1, 2, 3, or 4.
- Orifice Size and Valve Angle.
- Inlet Pressure.
- Normal Outlet Pressure Set-Point.
- Set-Point for Monitor.
- Upstream or Downstream Monitor (if not specified, upstream will be furnished).
- Capacity Required (SCFH).
- Type of Gas (natural gas, propane, air, etc.).
- Spring (normally operating regulator).
- Spring (monitor).
- Options: IRV (should normally be used on monitor), Monitor Indicator, Model 137 Vent, 1/4" NPT Taps (on inlet, intermediate or outlet).