



Regulator Installation and Maintenance Instructions

Model 121 Regulators

Introduction

The Model 121 Regulator represents a combination of capacity, performance and value...

Streamlined body passages provide large capacity. An external control line is required from lower case to control piping. The 121 has a fast speed of response, yet is stable in operation. Soft seats assure positive tight shutoff. Orifices are replaceable. Springs are color coded.

And it is also available as a zero governor or atmospheric regulator, a differential regulator, a relief valve or backpressure regulator, vacuum regulator or vacuum breaker.

Installation

1. Examine the regulator for shipping damage.
2. Check nameplate data. Be sure regulator conforms with what was ordered.
3. Inside of regulator and piping must be clean and free of dirt. Remove all dirt and debris before installing regulator. Failure to remove dirt/debris could result in regulator damage or trouble.
4. Remove all shipping screens and covers from the regulator. Do not let dirt get inside the regulator.
5. Install the regulator. Make sure the inlet and outlet are correctly connected. High pressure connects to the inlet. The flow arrow must point downstream.
6. Screwed connections must conform with good piping practice free of excess thread engagement per ANSI B2.1 Apply pipe joint compound to male threads only.
7. The Model 121 Regulator is usually right side-up as shown on the Typical Installation drawing (See Page 2). It may, however, be installed upside down. Although, when inverted it may be necessary to readjust the set-point.

Caution: Do not install sideways. The diaphragm should be horizontal.

8. On indoor installations requiring venting outdoors, run the vent piping as short and direct as possible with minimum bends and elbows. Use the same size or larger pipe as the vent connections on the regulator. With natural gas, or any other hazardous gas, vent to a safe place outdoors in case gas should accidentally be discharged. Screen and protect the opening outdoors to guard against water, ice, dirt, debris or insects. Install the control line. Connect it into the outlet piping at least 5 pipe diameters downstream from the regulator.

CAUTIONS:

- a. On backpressure regulators and relief valves the external control line connects into the **inlet** piping, 5 pipe diameters upstream from the regulator.
- b. Do not install any automatic shutoff device that closes completely between the regulator and the control line connection into the piping.

To avoid excessive turbulence, the connection should be clean and smooth on the inside and be located in straight pipe clear of valves and fittings. Keep the inside of the control line clean and protect it from corrosion. Pitch it away from the regulator and avoid moisture pockets. It must be strong ($1/4$ " for 121-8 and 121-12, $1/2$ " for 121-16, or larger steel tubing or pipe is preferred). It must be well protected against breakage (remember...regulators open wide if the control line breaks).

9. Make sure the regulator is correctly connected and adequately supported and pipe joints are tight.

Start-Up

- A. The inlet and outlet shutoff valves should both be closed. If a by-pass is used, the by-pass valve should also be closed.
- B. Note the set-point (set-point is the outlet pressure the regulator is adjusted to deliver). Regulator is factory adjusted to the set-point specified on the order.

CAUTION: This caution applies where the piping downstream of the outlet shutoff valve is pressured. That pressure must not exceed the regulator set-point by more than the pressure noted (see "Maximum Emergency Pressures", Page 18).

- C. Slowly and carefully open the **inlet** shutoff valve just enough to allow **inlet pressure** to build up slowly in the regulator until it is fully pressured.

CAUTION: During start-up, a pressure gauge must be used on the regulator **outlet** pressure and carefully watched. While **inlet** pressure builds up, **outlet** pressure must not exceed set-point by more than 1 psi. If **outlet** pressure begins to exceed set-point by more than 1 psi, close the **inlet** shutoff valve. This indicates the regulator is not closing properly. Check and make necessary corrections before proceeding with start-up. If regulator **outlet** pressure exceeds set-point by more than the pressure noted, refer to "Maximum Emergency Pressures", Page 18 for instructions.

- D. Check installation for leaks.
- E. Slowly open the outlet shutoff valve to allow a small flow (approximately 1000 SCFH). Make sure the flow of gas does not create a hazard.

NOTE: If piping downstream of outlet shutoff valve is pressured, see "CAUTION" under B.
- F. With gas flowing, check for correct inlet and outlet pressures. It may be necessary to further open the inlet shutoff valve to maintain full inlet pressure.
- G. Make sure the regulator closes tight (tight lock-up). To do this, reduce flow to zero by slowly closing the outlet shutoff valve. Outlet pressure should not exceed set-point by more than 6" w.c.
- H. Fully open inlet and outlet shutoff valves. Do this slowly and carefully. Watch pressure gauges.
- I. Complete start-up by making sure there are no leaks.

NOTE

- Do not exceed the regulator's pressure ratings. The regulator outlet has a lower pressure rating than the inlet. Do not expose the regulator outlet or control line to inlet pressure.

Regulator with external control may be used as an upstream monitor or upstream regulator in a monitor set. The control line must connect into the outlet piping downstream of the downstream regulator.

- If the regulator is to be moved to another location, make sure its construction is compatible with the pressure and flow conditions.

Temperature Limits

The Model 121 Regulator can be used for flowing temperatures from -20°F to 150°F .

Buried Service

The Model 121 Regulator is not recommended for buried service.

Set Point Adjustment

A. The 121 is factory adjusted as specified on the order. To change the set-point, readjust as follows:

1. Remove the top cap **1**.
2. Adjust set-point with adjustment button **3**, **3a** or **6**. Turn clockwise to increase and counterclockwise to decrease the outlet pressure.

NOTE: a. Only make this adjustment when gas is actually flowing through the regulator. The flow should be small (approximately 1000 SCFH). Do not adjust when the regulator is closed and there is no flow.

- b. Do not increase the set-point beyond the upper limit of the outlet pressure range for the spring **9** (refer to spring tables, Page 3).
- c. Always check the outlet pressure with a pressure gauge while adjusting the set-point.

3. When adjustment is complete, replace top cap **1**. Screw it securely into place. Leaving it off could cause unstable regulator operation.

CAUTION

It is the user's responsibility to assure that all regulator vents and/or vent lines exhaust to a non-hazardous location away from any potential sources of ignition. Where vent lines are used, it is the user's responsibility to assure that each regulator is individually vented and that common vent lines are not used.

To Change Spring

A. The outlet pressure ranges of spring **9** are given in the tables on Pages 3 and 4. To change the spring:

1. Remove top cap **1**.
2. Unscrew and remove adjustment button **3**, **3a** or **6** by turning counterclockwise, and remove spring **9**.
3. Insert new spring. Make sure it is positioned correctly at the bottom before replacing adjustment button **3**, **3a** or **6**.
4. Adjust for the desired outlet pressure per previous section "Set Point Adjustment".
5. When adjustment is complete, replace top cap **1**. Screw it securely into place. Leaving it off could result in unstable regulator operation.
6. New spring range should be marked on regulator. If old spring range appears on regulator, it should be removed.

CAUTION

The diaphragm case vent must be positioned to protect against flooding, drain water, ice formation, traffic, tampering, etc. The vent must be protected against nest building animals, bees, insects, etc. to minimize the chances for foreign material from collecting in the vent side of the regulator diaphragm.

Shutdown

A. To take the regulator out of service, close the **inlet** stop valve first. Close it carefully. Then close the **outlet** stop valve.

Before working on regulator, read the next section "General Servicing Instructions" and the applicable servicing instructions.

CAUTION

Turn gas on very slowly. If an outlet stop valve is used, it should be opened first. Do not overload diaphragm with a sudden surge of inlet pressure. Monitor the outlet pressure during start-up to prevent an outlet pressure overload.

General Servicing Instructions

- A. Before any disassembly of the regulator make sure it is completely depressured. Pressure must be fully released from the inlet, the outlet and the control line connection. Failure to adequately depressure could result in serious personal injury.
- B. Carefully note the location and position of all disassembled parts to be certain reassembly is correct. Inspect each part carefully and replace any that are worn or damaged or otherwise unsatisfactory.
- C. Upon completion of servicing, make certain that the regulator installation is entirely free of leaks.

CAUTION

Regulators are pressure control devices with numerous moving parts subject to wear that are dependent upon particular operating conditions. To assure continuous satisfactory operation, a periodic inspection schedule must be adhered to with the frequency of inspection determined by the severity of service and applicable laws and regulations.

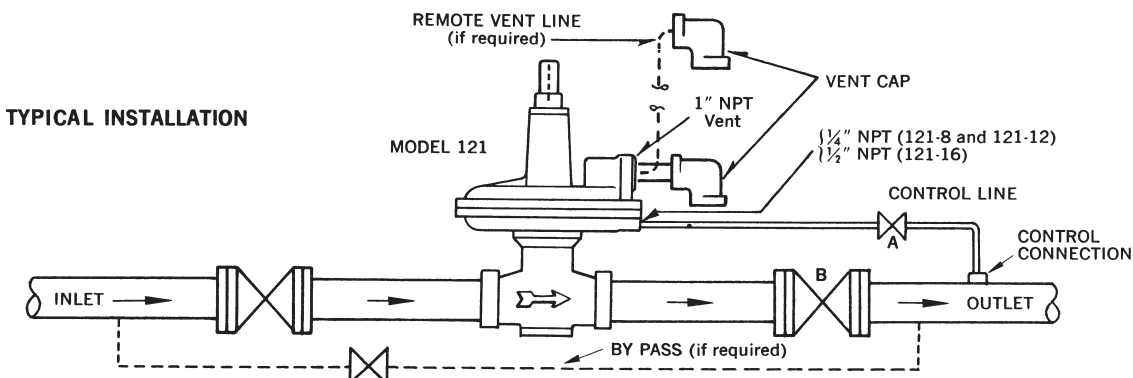

Outlet Pressure Ranges and Springs

SIZE	OUTLET PRESSURE RANGE	SPRING COLOR	SPRING PART NUMBER	MAXIMUM INLET PRESSURE	NOMINAL DIAPHRAGM SIZE
3/4", 1" and 1 1/4"*** Model 121-8	1 1/2" to 3 1/2" w.c.	Blue-Black Black-Red	143-82-021-01 (main spring) 121-10-021-50 (counterspring)	60 psi	8"
	1 1/2" to 12" w.c.	Green-Black Black-Red	143-82-021-02 (main spring) 121-10-021-50 (counterspring)		
	3 1/2" to 6 1/2" w.c. 5" to 8 1/2" w.c. 6" to 14" w.c. 12" to 28" w.c. 1 psi to 2 psi 2 psi to 4 1/4 psi	Red-Black Blue-Black Green-Black Green (2" O.D.) Orange (2" O.D.) Black	143-82-021-00 143-82-021-01 143-82-021-02 143-16-021-05 143-16-021-06 143-16-021-07		
3/4", 1" and 1 1/4"*** Model 121-8HP	3 psi to 6 1/2 psi	Cadmium*	143-16-021-08	60 psi	8"
	6 psi to 10 psi	Cadmium* White	143-16-021-08 (outer) 143-16-021-13 (inner)		
1 1/2", 2" and 2 1/2" Model 121-12	1 1/2" to 3 1/2" w.c.	Red –	143-16-021-03 (main spring) 120-10-021-10 (counterspring)	60 psi	12"
	1 1/2" to 12" w.c.	Maroon –	121-42-021-00 (main spring) 120-10-021-10 (counterspring)		
	3 1/2" to 6 1/2" w.c. 5" to 8 1/2" w.c. 6" to 14" w.c. 12" to 28" w.c. 1 psi to 2 psi 1 1/2 psi to 3 psi	Red (2" O.D.) Blue (2" O.D.) Green (2" O.D.) Orange (2" O.D.) Black Cadmium	143-16-021-03 143-16-021-04 143-16-021-05 143-16-021-06 143-16-021-07 143-16-021-08		
1 1/2", 2" and 2 1/2" Model 121-8	1 psi to 2 psi 2 psi to 4 1/4 psi	Orange (2" O.D.) Black	143-16-021-06 143-16-021-07	60 psi	8"
1 1/2", 2" and 2 1/2" Model 121-8HP	3 psi to 6 1/2 psi	Cadmium*	143-16-021-08	60 psi	8"
	6 psi to 10 psi	Cadmium* White	143-16-021-08 (outer) 143-16-021-13 (inner)		
3" and 4" Model 121-16	3 1/2" to 6 1/2" w.c. 5" to 8 1/2" w.c. 6" to 14" w.c. 14" to 28" w.c. 1/2 psi to 1 1/4 psi	Red (3" O.D.) Blue (3" O.D.) Green (3" O.D.) Orange (3" O.D.) Yellow	121-62-021-50 121-62-021-51 121-62-021-52 121-62-021-53 121-62-021-56	40 and 15†	16"
3" and 4" Model 121-12	1 psi to 2 psi 1 1/2 psi to 3 psi	Black Cadmium	143-16-021-07 143-16-021-08	40 and 15†	12"

*Requires High Pressure Spring Adjustment.

†3" 121 is 40 psi. and 4" 121 is 15 psi. ***3/4" x 3/4" not available.

Atmospheric Regulator or Zero Governor

SIZE	OUTLET PRESSURE RANGE	SPRINGS
3/4", 1" and 1 1/4" 121-8	1 1/2" w.c. vacuum (–1 1/2" w.c.) to + 1 1/2" w.c.	Main Spring (Red-Black) 143-82-021-00 Counterspring (Red-Black) 121-10-021-50
1 1/2", 2" and 2 1/2" 121-12	1" w.c. vacuum (–1" w.c.) to + 1 1/2" w.c.	Main Spring (Red-Black) 143-82-021-00 Counterspring 120-10-021-10
3" and 4" 121-16	1 1/4" w.c. vacuum (–1 1/4" w.c.) to +1 1/4" w.c.	Main Spring only 121-62-021-54

Differential Regulator

SIZE	DIFFERENTIAL PRESSURE RANGE	SPRING COLOR	SPRING PART NUMBER	MAXIMUM BODY PRESSURE	MAXIMUM DIAPHRAGM PRESSURE DIFFERENTIAL	MAXIMUM DIAPHRAGM CASE PRESSURE
3/4", 1" and 1 1/4" 121-8**	3 1/2" to 6 1/2" w.c. 5" to 8 1/2" w.c. 6" to 14" w.c. 12" to 28" w.c. 1 psi to 2 psi	Red-Black Blue-Black Green-Black Green Orange (2" O.D.)	143-82-021-00 143-82-021-01 143-82-021-02 143-16-021-05 143-16-021-06	60 psi	2 psi	35 psi
1 1/2", 2" and 2 1/2" 121-12	3 1/2" to 6 1/2" w.c. 5" to 8 1/2" w.c. 6" to 14" w.c. 12" to 28" w.c. 1 psi to 2 psi	Red (2" O.D.) Blue (2" O.D.) Green (2" O.D.) Orange (2" O.D.) Black	143-16-021-03 143-16-021-04 143-16-021-05 143-16-021-06 143-16-021-07	60 psi	2 psi	20 psi
3" and 4" 121-16	3 1/2" to 6 1/2" w.c. 5" to 8 1/2" w.c. 6" to 14" w.c. 12" to 28" w.c.	Red (3" O.D.) Blue (3" O.D.) Green (3" O.D.) Orange (3" O.D.)	121-62-021-50 121-62-021-51 121-62-021-52 121-62-021-53	40 and 15*	1 psi	10 psi
3" and 4" 121-12	1 psi to 2 psi 1 1/2 psi to 3 psi	Black Cadmium	143-16-021-07 143-16-021-08	40 and 15*	2 psi	20 psi

*3" 121-16 is 40 psi. and 4" 121-16 is 15 psi. **3/4" x 3/4" not available.

Back Pressure Regulator or Relief Valve

SIZE	RELIEF OR BACK PRESSURE RANGE	SPRING COLOR	PART NUMBER	MAX. DIAPHRAGM CASE PRESSURE
3/4" thru 2 1/2" 121-8**	3" to 5 1/2" w.c. 5" to 7 1/2" w.c. 6" to 13" w.c. 10" to 15" w.c. 12" to 25" w.c. 18" w.c. to 2 psi 1 psi to 4 psi	Red-Black Blue-Black Green-Black Blue (2" O.D.) Green (2" O.D.) Orange (2" O.D.) Black	143-82-021-00 143-82-021-01 143-82-021-02 143-16-021-04 143-16-021-05 143-16-021-06 143-16-021-07	10 psi
3/4" thru 2 1/2" 121-8**	3 psi to 6 psi 6 psi to 10 psi	Cadmium* [Cadmium (outer)* White (inner)]	143-16-021-08 143-16-021-08 143-16-021-13	20 psi
1 1/2", 2" and 2 1/2" 121-12	3" to 5 1/2" w.c. 5" to 7" w.c. 6" to 12" w.c. 12" to 25" w.c.	Red (2" O.D.) Blue (2" O.D.) Green (2" O.D.) Orange (2" O.D.)	143-16-021-03 143-16-021-04 143-16-021-05 143-16-021-06	10 psi
1 1/2" thru 4" 121-12	20" w.c. to 1 3/4 psi 1 1/2" to 2 3/4 psi	Black Cadmium	143-16-021-07 143-16-021-08	
3" and 4" 121-16	3" to 4 1/2" w.c. 3" to 6" w.c. 5" to 11" w.c. 10" to 24" w.c. 14" w.c. to 1 1/4 psi	Red (3" O.D.) Blue (3" O.D.) Green (3" O.D.) Orange (3" O.D.) Yellow	121-62-021-50 121-62-021-51 121-62-021-52 121-62-021-53 121-62-021-56	5 psi

*Require High Pressure Spring Adjustment (121-8HP). **3/4" x 3/4" not available.

3/4", 1" and 1 1/4" Model 121

Standard, Differential, Atmospheric or Zero Governors

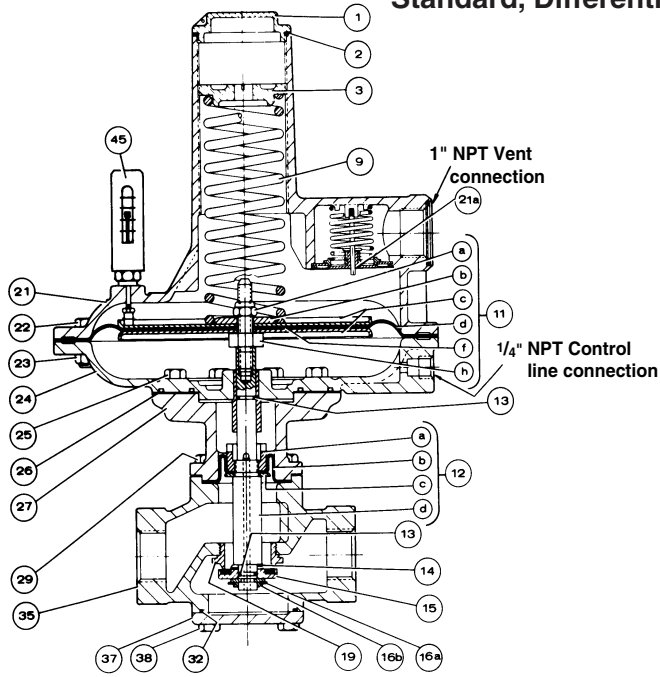

121-8 (Standard)

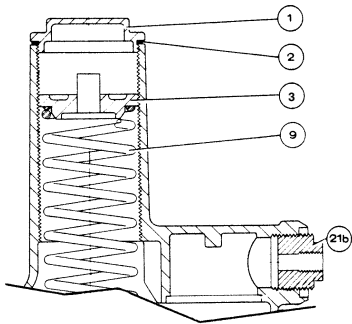
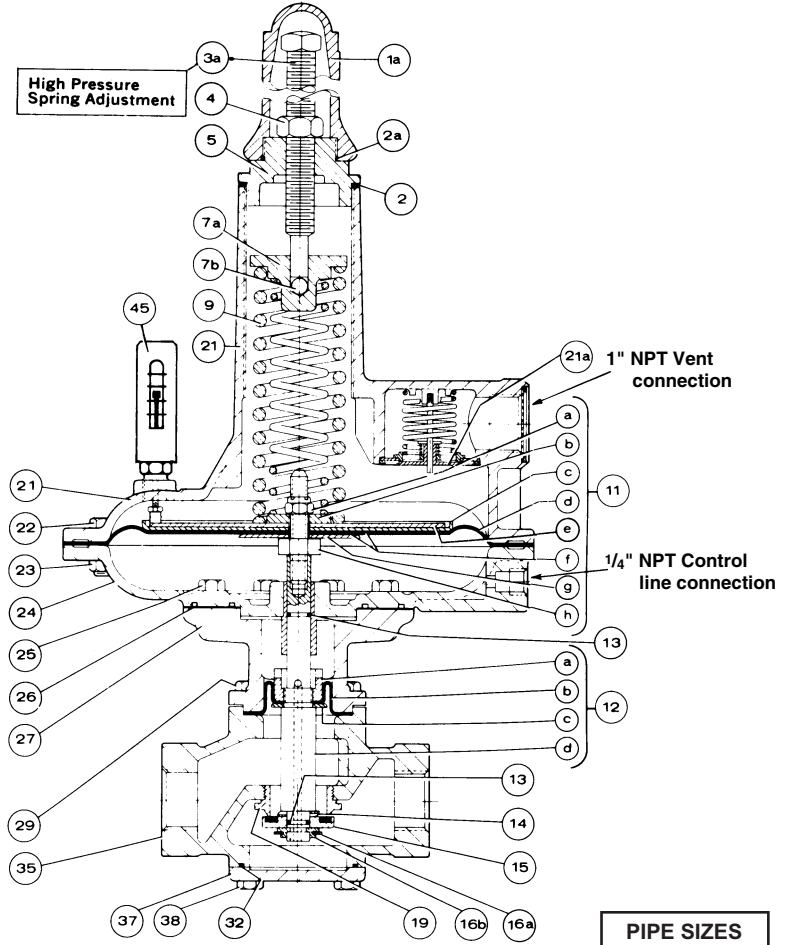

Fig. 1
ADJUSTMENT 3
and VENT CONNECTION
21b for Differential Regulators,
Atmospheric Regulators
and Zero Governors



121-8 HP (High Pressure)

PIPE SIZES (inlet x outlet) Screwed, NPT
3/4" x 1"
3/4" x 1 1/4"
1" x 1"
1" x 1 1/4"
1 1/4" x 1 1/4"

3/4", 1" and 1 1/4" Model 121

Back Pressure

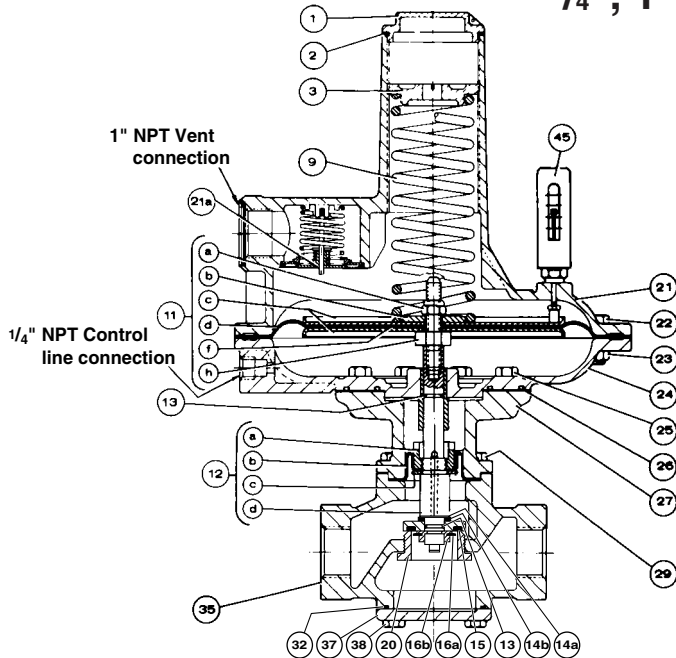

121-8 (Back Pressure)

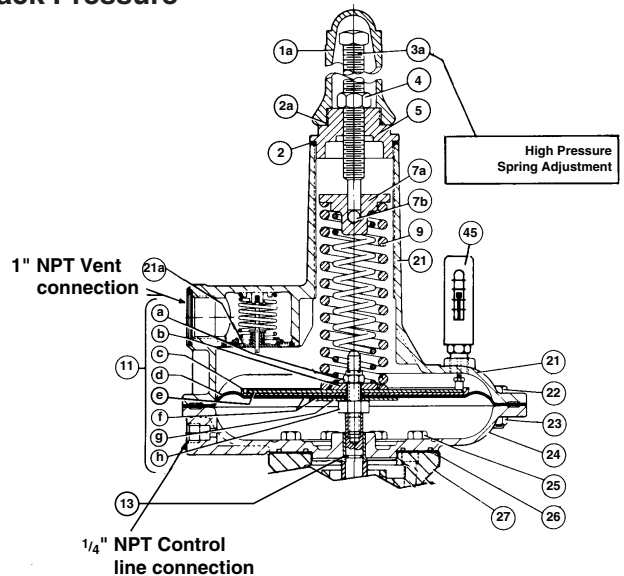

121-8 HP (High Pressure)
(Back Pressure)

Condensed Parts List $\frac{3}{4}$ ", 1" and $1\frac{1}{4}$ "

ILL. NO.	DESCRIPTION	PART NUMBER
1	Seal Cap	143-16-005-00
1a	Seal Cap	121-10-005-52
2	Tetraseal (or O-Ring) $2\frac{1}{4}$ " x $2\frac{3}{8}$ "	905241
2a	Tetraseal (or O-Ring) $1\frac{1}{2}$ " x $1\frac{5}{8}$ "	906534
3	Adjustment Spring Button	143-16-009-00
3a	Spring Adjusting Screw	906537
4	Jam Nut $\frac{1}{2}$ "-13	921005
5	Housing Cover	121-10-005-51
7a	Top Spring Button	121-10-009-51
7b	Thrust Bearing, stainless ball, $\frac{3}{8}$ " diameter	930510
9	Spring, see table "Spring Ranges"	
11	121-8 Standard Diaphragm Assembly (3 $\frac{1}{2}$ " w.c. to 4 $\frac{1}{4}$ " psi outlet pressure)	121-10-550-52
	11a Elastic Stop Nut 52-NTE-066	908561
	11b Bottom Spring Button	121-10-022-50
	11c Diaphragm Pan	121-10-017-50
	11d Diaphragm, Buna-N	121-10-150-50
	11d Diaphragm, Viton	121-10-150-52
	11f Seal Washer	121-10-178-50
	11h Diaphragm Stud, Stainless Steel	091-16-058-02
11	121-8 HP High Pressure Diaphragm Assembly (3 psi to 10 psi outlet pressure)	121-10-550-55
	11a Elastic Stop Nut 29-NE-066	903955
	11b Bottom Spring Button	121-10-022-53
	11c Diaphragm Pan	121-10-017-50
	11d Diaphragm, Buna-N	121-10-150-50
	11d Diaphragm, Viton	121-10-150-52
	11e Upper Plate	121-10-022-52
	11f Seal Washer	121-10-178-50
	11g Lower Plate	121-10-079-52
	11h Diaphragm Stud, Stainless Steel	091-16-058-02
12	121 Seal Diaphragm Assembly	121-16-564-51
	12a Piston	121-10-053-51
	12b Seal Diaphragm, Buna-N	121-10-364-50
	12b Seal Diaphragm, Viton	121-10-364-51
	12c Plate	121-10-010-53
	12d Stem, Stainless Steel	121-10-016-53
13	O-Ring, Buna-N, $\frac{3}{8}$ " x $\frac{1}{2}$ "	934007
	O-Ring, Viton, $\frac{3}{8}$ " x $\frac{1}{2}$ "	902418

ILL. NO.	DESCRIPTION	PART NUMBER
14	Wave Washer	905479
15	Molded Valve, Buna-N (45-50 Duro)	121-10-311-50
	Molded Valve, Viton-A (65-75 Duro)	121-10-311-51
16a	Retaining Ring	904447
	Pliers for retaining ring 16a, Truarc 0200	1190646
16b	Valve Holder, split (pair required), stainless steel	121-16-130-51
19	Orifice, $1\frac{1}{4}$ " dia., brass	143-16-023-03
	Orifice, $1\frac{1}{4}$ " dia., stainless steel	143-16-023-14
26	Gasket	121-16-063-51
32	Tetraseal (or O-Ring) $2\frac{3}{8}$ " x $2\frac{1}{2}$ "	904081
45	Travel Indicator (specify scale 091-00-008-06)	091-00-365-00
46	Repair Kits, consisting of Buna-N Main and Seal Diaphragms, Buna-N Molded Valve plus Wave Washer and Retaining Ring, Buna-N O-Rings, Tetraseals and Gaskets: For 121-8 For 121-8 HP	121-10-598-50 121-10-598-51
FOR BACK PRESSURE MODELS		
12	Item 12d above, Stem, Stainless Steel - substitute	121-10-016-55
	Stem, Back Pressure	
14	Item 14 above, Wave Washer - substitute	121-16-102-52 121-16-103-50
	Poly-U Disk	
	Retainer	121-10-023-50
19	Item 19 above, Orifice - substitute	121-10-023-51
	Orifice, Back Pressure (Brass)	
	Orifice, Back Pressure (Stainless Steel)	
46	Item 46 above, Repair Kits - substitute	
	For 121-8 Back Pressure	121-10-598-54
	For 121-8 HP Back Pressure	121-10-598-55
47	Add Item 47 Valve, Seal Diaphragm and Stem Assembly	121-10-511-52

Servicing – General Instructions

1. Make sure the regulator is entirely depressured before servicing.
2. Carefully note location and position of all disassembled parts to be certain reassembly is correct. Inspect each one carefully and replace those that are worn or damaged or otherwise unsatisfactory.
3. A moderate application of lubricant to O-ring **13** will help assure free stem movement and a tight seal. Similar application of lubricant to the other O-rings or Tetraseals will help assure their tightness.
Do not use petroleum base lubricants.
4. Bolted connections should be tightened evenly and firmly. Carefully tighten diaphragms into place. Bolts must be tight enough to prevent leakage, but not so tight that the diaphragm material is crushed or damaged.
5. Upon completion of servicing, make certain that regulator installation is entirely free of leaks.

To Service Valve (15)

1. Remove bolts **38** and remove bottom cap **37** and Tetraseal **32**.
 2. Remove retaining ring **16a**. Use Truarc 0200 pliers. Invensys Part No. 1190646.
 3. Remove both halves of valve holder **16b**.
 4. Remove valve **15** (wave washer **14** will probably also come off...do not lose it).
- To reassemble, replace parts in reverse sequence.

To Service Main Diaphragm (11d)

1. Remove top cap **1**, and release and remove adjustment **3**, **3a** or **6**.
On high pressure Model remove cap **1a**, release adjustment **3a**, and remove cover **5** and button **7a**.
Mark or measure position of adjustment **3**, **3a** or **6**. Use this to return adjustment to this setting during reassembly.
 2. Remove spring **9**.
 3. Remove bolts **22** and upper case **21**.
 4. Rotate diaphragm assembly **11** counterclockwise (this unscrews **11h** from **12d**) and remove.
 5. To disassemble diaphragm assembly, remove nut **11a**. Carefully note location and position of all parts to be certain of correct reassembly. Abrasive side of emery cloth washers face against diaphragm.
- To reassemble, replace parts in reverse sequence.
Make the screwed connection between 11h and 12d loose by approximately 1/2 turn. To do this, carefully rotate diaphragm assembly **11** clockwise until this screwed connection bottoms (do not jam it together). Then, back-off diaphragm assembly **11** counter-clockwise approximately 1/2 turn...this is very important...the **11h** to **12d** screwed connection must not be tight.

To Service Orifice (19)

1. Remove valve **15** per section "To Service Valve (15)".
2. Unscrew orifice **19** using 15/8" hex socket wrench.
When replacing orifice use a moderate amount of pipe dope on orifice threads.

To Service Seal Diaphragm (12b)

1. Remove valve **15** per section "To Service Valve (15)".
 2. Remove diaphragm assembly **11** per section "To Service Main Diaphragm (11d)".
 3. Remove bolts **25** and lower diaphragm case **24**.
 4. Remove bolts **29** and centerpiece **27**, and then remove seal diaphragm assembly **12**.
 5. To disassemble **12**, unscrew piston **12a** from stem **12d**. Use a spanner wrench in notch in skirt of piston (this can also be done by inserting a standard 7/32" Allen wrench in the notch).
- To reassemble, replace parts in reverse sequence.
Make certain that fabric side of seal diaphragm **12b** faces upward and "rubber" side faces downward toward body.
Do not pinch loop in seal diaphragm **12b** between **35** and center-piece **27**.

Servicing – Back Pressure Models General Instructions

1. Make sure the regulator is entirely depressured before servicing.
2. Carefully note location and position of all disassembled parts to be certain reassembly is correct. Inspect each one carefully and replace those that are worn or damaged or otherwise unsatisfactory.
3. A moderate application of lubricant to O-ring **13** will help assure free stem movement and a tight seal. Similar application of lubricant to the other O-rings or Tetraseals will help assure their tightness.
Do not use petroleum base lubricants.
4. Bolted connections should be tightened evenly and firmly. Carefully tighten diaphragms into place. Bolts must be tight enough to prevent leakage, but not so tight that the diaphragm material is crushed or damaged.
5. Upon completion of servicing, make certain that regulator installation is entirely free of leaks.

To Service Valve (15)

1. Remove bolts **29** and remove upper case assembly.
 2. Remove retaining ring **16a**. Use Truarc 0200 pliers. Invensys Part No. 1190646.
 3. Remove both halves of valve holder **16b**.
 4. Remove valve **15** (washer **14A** and holder **14B** will probably also come off...do not lose them).
- To reassemble, replace parts in reverse sequence.

To Service Main Diaphragm (11d)

1. Remove top cap **1**, and release and remove adjustment **3**. On high pressure Model remove cap **1a**, release adjustment **3a**, and remove cover **5** and button **7a**.
Mark or measure position of adjustment **3** or **3a**. Use this to return adjustment to this setting during reassembly.
 2. Remove spring **9**.
 3. Remove bolts **22**, nuts **23**, and upper case **21**.
 4. Rotate diaphragm assembly **11** counterclockwise (this unscrews **11h** from **12d**) and remove.
 5. To disassemble diaphragm assembly, remove nut **11a**. Carefully note location and position of all parts to be certain of correct reassembly. Abrasive side of emery cloth washers face against diaphragm.
- To reassemble, replace parts in reverse sequence.
Make the screwed connection between 11h and 12d loose by approximately 1/2 turn. To do this, carefully rotate diaphragm assembly **11** clockwise until this screwed connection bottoms (do not jam it together). Then, back-off diaphragm assembly **11** counterclockwise approximately 1/2 turn...this is very important...the **11h** to **12d** screwed connection must not be tight.

To Service Orifice (20)

1. Remove top cap **1**, and release and remove adjustment **3**. On high pressure Model remove cap **1a**, release adjustment **3a**, and remove cover **5** and button **7a**.
Mark or measure position of adjustment **3** or **3a**. Use this to return adjustment to this setting during reassembly.
 2. Remove spring **9**.
 3. Remove bolts **38** and bottom cap **37** along with Tetraseal **32**.
 4. Unscrew orifice **20** using 15/8" hex socket wrench. When replacing orifice use a moderate amount of pipe dope on orifice threads.
- To reassemble, replace parts in reverse sequence.

To Service Seal Diaphragm (12b)

1. Remove bolts **29**, upper case assembly, and then remove seal diaphragm, and stem assembly **12**.
 2. To disassemble **12**, unscrew piston **12a** from stem **12d**. Use a spanner wrench in notch in skirt of piston (this can also be done by inserting a standard 7/32" Allen wrench in the notch).
- To reassemble, replace parts in reverse sequence. Make certain that fabric side of seal diaphragm **12b** faces upward and "rubber" side faces downward toward body.
Do not pinch loop in seal diaphragm **12b** between **35** and center-piece **27**.

1½", 2" and 2½" Model 121

Standard, Differential, Atmospheric or Zero Governors

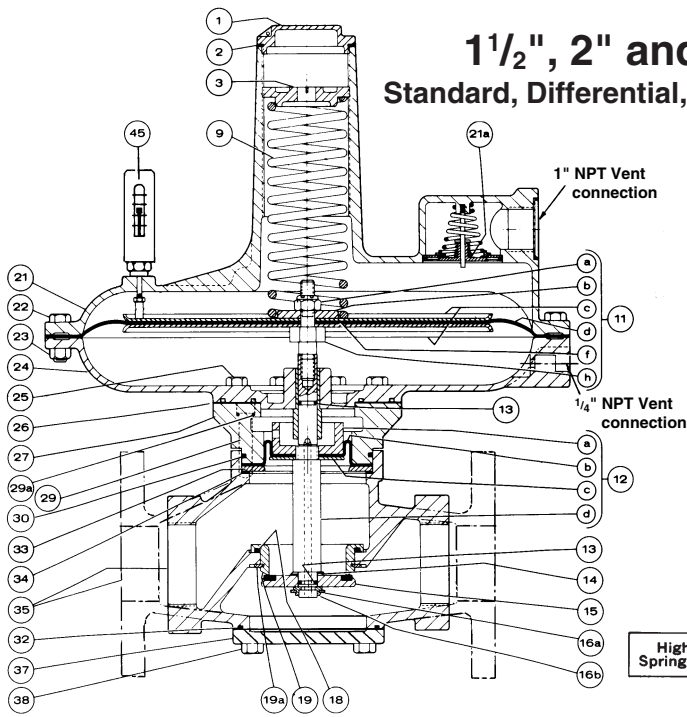

121-12 (Standard)

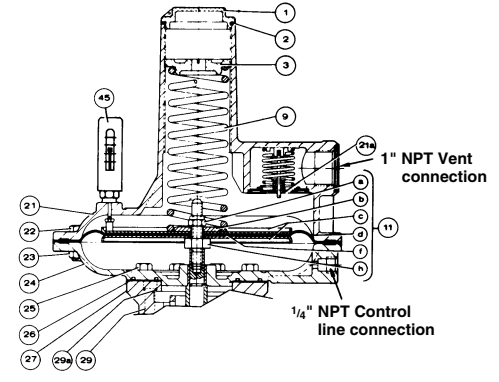

121-8 (Standard)

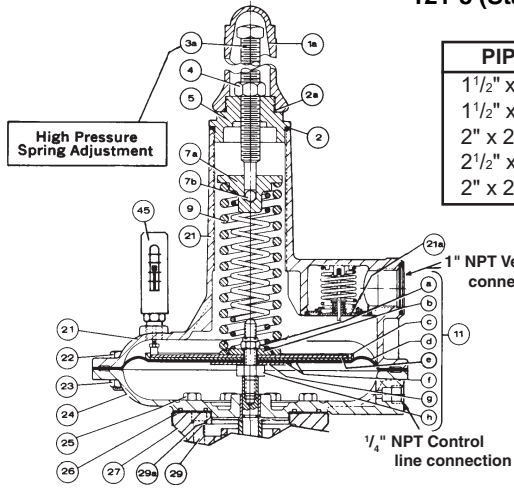

121-8 HP (High Pressure)

PIPE SIZES (inlet x outlet)	
1½" x 1½"	Screwed, NPT
1½" x 2"	
2" x 2"	
2½" x 2½"	
2" x 2" Flanged ANSI 125 lb. FF	

Fig. 1
ADJUSTMENT 3
and VENT CONNECTION
21b for Differential Regulators,
Atmospheric Regulators
and Zero Governors

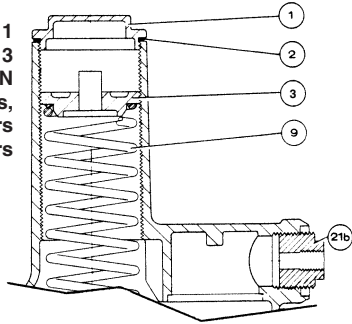

1½", 2" and 2½" Model 121

Back Pressure

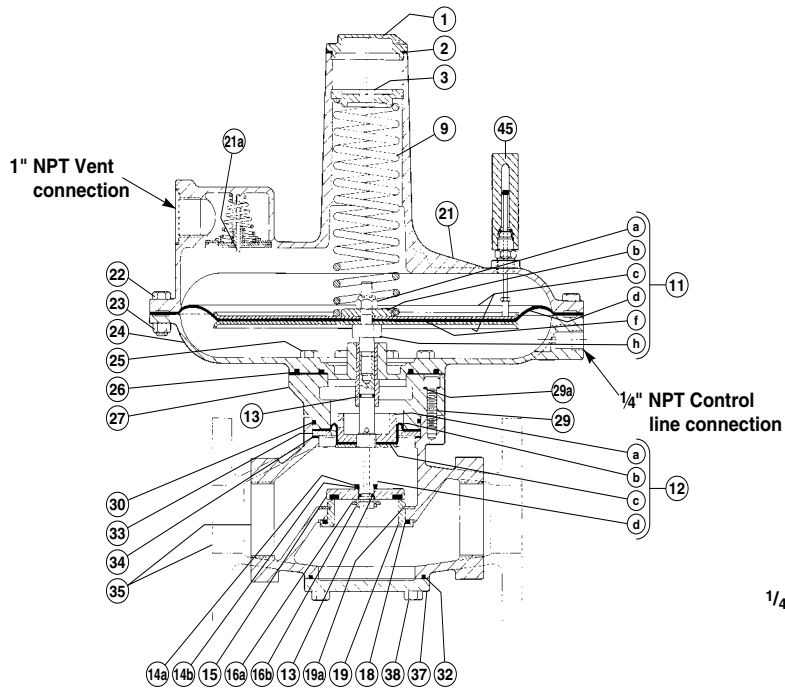

121-12 (Back Pressure)

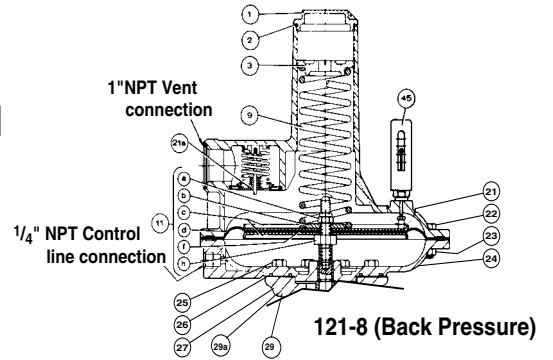

121-8 (Back Pressure)

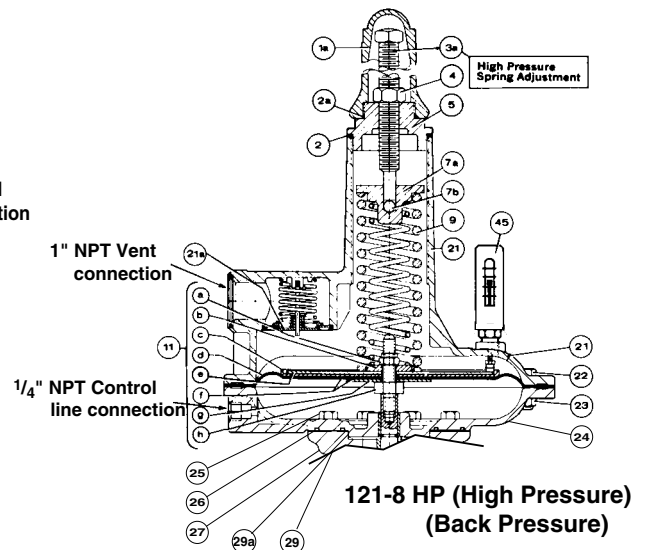

121-8 HP (High Pressure)
(Back Pressure)

Condensed Parts List 1½", 2" and 2½"

ILL. NO.	DESCRIPTION	PART NUMBER	ILL. NO.	DESCRIPTION	PART NUMBER
1	Seal Cap	143-16-005-00	13	O-Ring, Buna-N, 3/8" x 1/2"	934007
1a	Seal Cap	121-10-005-52		O-Ring, Viton, 3/8" x 1/2"	902418
2	Tetraseal (or O-Ring) 2¼" x 2³/8"	905241	14	Wave Washer	905479
2a	Tetraseal (or O-Ring) 1½" x 1⁵/8"	906534	15	Molded Valve, Buna-N (45-50 Duro)	121-16-311-50
3	Adjustment Spring Button	143-16-009-00		Molded Valve, Viton-A (65-75 Duro)	121-16-311-51
3a	Spring Adjusting Screw	906537	16a	Retaining Ring	904447
4	Hex Steel Nut	921005		Pliers for retaining ring 16a, Truarc 0200	1190646
5	Housing Cover	121-10-005-51	16b	Valve Holder, split (pair required), stainless steel	121-16-130-51
7a	Top Spring Button	121-10-009-51	18	Tetraseal (or O-Ring) 2½" x 2¹¹/₁₆"	904207
7b	Thrust Bearing, stainless ball, 3/8" diameter	930510	19	Orifice, 2⁵/₃₂" dia., steel	121-16-023-51
9	Spring, see table "Spring Ranges"			Orifice, 2⁵/₃₂" dia., stainless steel	121-16-023-52
11	121-12 Diaphragm Assembly (3½" w.c. to 2 psi outlet pressure)	121-16-550-51	19a	Retaining Ring, stainless	904657
	11a Elastic Stop Nut 52-NTE-066	908561		Pliers for retaining ring 19a, Truarc 0600	1190648
	11b Bottom Spring Button	121-10-022-50	26	Gasket	121-16-063-51
	11c Diaphragm Pan	121-16-017-50	29a	Copper Washer	121-16-178-51
	11d Molded Diaphragm, Buna-N	121-16-150-53	30	O-Ring, 3/8" x 3½"	934041
	11d Diaphragm, Viton	121-16-150-55	32	Tetraseal (or O-Ring) 3¼" x 3½"	904078
	11f Seal Washer	121-10-178-50	33	Seal Diaphragm Ring	121-16-008-50
	11h Diaphragm Stud, stainless steel	121-16-058-52	34	Gasket	121-16-104-50
11	121-8 Standard Diaphragm Assembly (1 psi to 4¼ psi outlet pressure)	121-10-551-52	45	Travel Indicator	091-00-365-00
	11a Elastic Stop Nut 29-NE-066	903955	46	Repair Kits, consisting of Buna-N Main and Seal Diaphragms, Buna-N Molded Valve plus Wave Washer and Retaining Ring, Buna-N O-Rings, Tetraseals and Gaskets:	
	11b Bottom Spring Button	121-10-022-50		For 121-12	121-16-598-50
	11c Diaphragm Pan	121-10-017-50		For 121-8	121-86-598-50
	11d Diaphragm, Buna-N	121-10-150-50		For 121-8 HP	121-86-598-51
	11d Diaphragm, Viton	121-10-150-52			
	11f Seal Washer	121-10-178-50			
	11h Diaphragm Stud, stainless steel	091-16-058-02			
11	121-8 HP High Pressure Diaphragm Assembly (3 psi to 10 psi outlet pressure)	121-10-550-55		FOR BACK PRESSURE MODELS	
	11a Elastic Stop Nut 29-NE-066	903955	12	Item 12d above, Stem, Stainless Steel - substitute Stem, Back Pressure	121-16-016-55
	11b Bottom Spring Button	121-10-022-53	14	Item 14 above, Wave Washer - substitute Poly-U Disk Retainer	121-16-102-52 121-16-103-50
	11c Diaphragm Pan	121-10-017-50	46	Item 46 above, Repair Kits - substitute For 121-12 Back Pressure For 121-8 Back Pressure For 121-8 HP Back Pressure	121-16-598-52 121-86-598-54 121-86-598-55
	11d Diaphragm, Buna-N	121-10-150-50	47	Add Item 47 Valve, Seal Diaphragm and Stem Assembly	121-16-511-51
	11d Diaphragm, Viton	121-10-150-52			
	11e Upper Plate	121-10-022-52			
	11f Seal Washer	121-10-178-50			
	11g Lower Plate	121-10-079-52			
	11h Diaphragm Stud, stainless steel	091-16-058-02			
12	121 Seal Diaphragm Assembly	121-16-564-51			
	12a Piston	121-16-053-51			
	12b Seal Diaphragm, Buna-N	121-16-364-50			
	12b Seal Diaphragm, Viton	121-16-364-51			
	12c Plate	121-16-010-53			
	12d Stem, stainless steel	121-16-016-53			

Servicing – General Instructions

1. Make sure the regulator is entirely depressured before servicing.
2. Carefully note location and position of all disassembled parts to be certain reassembly is correct. Inspect each one carefully and replace those that are worn or damaged or otherwise unsatisfactory.
3. A moderate application of lubricant to O-ring **13** will help assure free stem movement and a tight seal. Similar application of lubricant to the other O-rings or Tetraseals will help assure their tightness.

Do not use petroleum base lubricants.

4. Bolted connections should be tightened evenly and firmly.
Carefully tighten diaphragms into place. Bolts must be tight enough to prevent leakage, but not so tight that the diaphragm material is crushed or damaged.
5. Upon completion of servicing, make certain that regulator installation is entirely free of leaks.

To Service Valve (15)

1. Remove bolts **38** and remove bottom cap **37** and Tetraseal **32**.
 2. Remove retaining ring **16a**. Use Truarc 0200 pliers, Invensys Part No. 1190646.
 3. Remove both halves of valve holder **16b**.
 4. Remove valve **15** (wave washer **14** will probably also come off...do not lose it).
- To reassemble, replace parts in reverse sequence.

To Service Main Diaphragm (11d)

1. Remove top cap **1**, and release and remove adjustment **3**. On high pressure Model remove cap **1a**, release adjustment **3a**, and remove cover **5** and button **7a**. Mark or measure position of adjustment **3** or **3a**. Use this to return adjustment to this setting during reassembly.
 2. Remove spring **9**.
 3. Remove bolts **22** and upper case **21**.
 4. Rotate diaphragm assembly **11** counterclockwise (this unscrews **11h** from **12d**) and remove.
 5. To disassemble diaphragm assembly, remove nut **11a**. Carefully note location and position of all parts to be certain of correct reassembly. Abrasive side of emery cloth washers face against diaphragm.
- To reassemble, replace parts in reverse sequence.

Make the screwed connection between 11h and 12d loose by approximately 1/2 turn. To do this, carefully rotate diaphragm assembly **11** clockwise until this screwed connection bottoms (do not jam it together). Then, back-off diaphragm assembly **11** counterclockwise approximately 1/2 turn...this is very important...the **11h** to **12d** screwed connection must not be tight.

To Service Orifice (19)

1. Remove valve **15** per section "To Service Valve (**15**)".
 2. Remove main diaphragm assembly **11** per steps 1 through 4 "To Service Main Diaphragm (**11d**)".
 3. Remove seal diaphragm assembly **12** per steps 3 and 4 under "To Service Seal Diaphragm (**12b**)".
 4. Remove retaining ring **19a**. Use Truarc 0600 pliers, Invensys Part No. 1190648.
 5. Remove orifice **19** through top opening.
- To reassemble, replace parts in reverse sequence.
(On reassembly, be sure that **19a** is fully seated in its groove. Also, beveled edge of **19a** faces downward toward bottom cap **37**.)

To Service Seal Diaphragm (12b)

1. Remove valve **15** per section "To Service Valve (**15**)".
 2. Remove main diaphragm assembly **11** per steps 1 through 4 "To Service Main Diaphragm (**11d**)".
 3. Remove bolts **25** and lower diaphragm case **24**.
 4. Remove bolts **29** and centerpiece **27**, and then remove seal diaphragm assembly **12**.
 5. To disassemble **12**, unscrew piston **12a** from stem **12d**. Use a spanner wrench in notch in skirt of piston (this can also be done by inserting a standard 7/32" Allen wrench in the notch).
- To reassemble, replace parts in reverse sequence.

Make certain that fabric side of seal diaphragm **12b** faces upward and "rubber" side faces downward toward body.

Do not pinch loop in seal diaphragm **12b** between ring **33** and centerpiece **27**. Also, rounded edge of **33** faces upward toward seal diaphragm **12b**.

Periodic Inspection: Regulators are pressure control devices with numerous moving parts subject to wear that is dependent upon particular operation conditions. To assure continuous satisfactory operation, a periodic inspection schedule must be adhered to with the frequency of inspections, determined by the severity of service and applicable laws and regulations.

Servicing – Back Pressure Models General Instructions

1. Make sure the regulator is entirely depressured before servicing.
2. Carefully note location and position of all disassembled parts to be certain reassembly is correct. Inspect each one carefully and replace those that are worn or damaged or otherwise unsatisfactory.
3. A moderate application of lubricant to O-ring **13** will help assure free stem movement and a tight seal. Similar application of lubricant to the other O-rings or Tetraseals will help assure their tightness.

Do not use petroleum base lubricants.

4. Bolted connections should be tightened evenly and firmly.

Carefully tighten diaphragms into place. Bolts must be tight enough to prevent leakage, but not so tight that the diaphragm material is crushed or damaged.

5. Upon completion of servicing, make certain that regulator installation is entirely free of leaks.

To Service Main Diaphragm (11d)

1. Remove top cap **1**, and release and remove adjustment **3**.

On high pressure Model remove cap **1a**, release adjustment **3a**, and remove cover **5** and button **7a**.

Mark or measure position of adjustment **3** or **3a**. Use this to return adjustment to this setting during reassembly.

2. Remove spring **9**.
 3. Remove bolts **22**, nuts **23**, and upper case **21**.
 4. Rotate diaphragm assembly **11** counterclockwise (this unscrews **11h** from **12d**) and remove.
 5. To disassemble diaphragm assembly, remove nut **11a**. Carefully note location and position of all parts to be certain of correct reassembly. Abrasive side of emery cloth washers face against diaphragm.
- To reassemble, replace parts in reverse sequence.

Make the screwed connection between 11h and 12d loose by approximately 1/2 turn. To do this, carefully rotate diaphragm assembly **11** clockwise until this screwed connection bottoms (do not jam it together). Then, back-off diaphragm assembly **11** counterclockwise approximately 1/2 turn...this is very important...the **11h** to **12d** screwed connection must not be tight.

To Service Seal Diaphragm (12b)

1. Remove main diaphragm assembly **11** per steps 1 through 4 "To Service Main Diaphragm (**11d**)".
3. Remove bolts **29** and centerpiece **27**, then remove seal diaphragm, valve and stem assembly **12**.
4. To disassemble **12**, unscrew piston **12a** from stem **12d**. Use a spanner wrench in notch in skirt of piston (this can also be done by inserting a standard 7/32" Allen wrench in the notch).

– To reassemble, replace parts in reverse sequence.

Make certain that fabric side of seal diaphragm **12b** faces upward and "rubber" side faces downward toward body.

Do not pinch loop in seal diaphragm **12b** between ring **33** and centerpiece **27**. Also, rounded edge of **33** faces upward toward seal diaphragm **12b**.

To Service Valve (15)

1. Remove main diaphragm assembly **11** per steps 1 through 4 "To Service Main Diaphragm (**11d**)".
2. Remove seal diaphragm, valve and stem assembly to service seal diaphragm (**12b**).
3. Remove retaining ring **16a**. Use Truarc 0200 pliers, Invensys Part No. 1190646.
4. Remove both halves of valve holder **16b**.
5. Remove valve **15** (washer **14** and holder **14a** will probably also come off...do not lose them).

– To reassemble, replace parts in reverse sequence.

To Service Orifice (19)

1. Remove main diaphragm assembly **11** per steps 1 through 4 "To Service Seal Diaphragm (**11d**)".
2. Remove seal diaphragm, valve and stem assembly **12** per steps 2 and 3 under "To Service Seal Diaphragm (**12b**)".
3. Remove retaining ring **19a** through top opening. Use Truarc 0600 pliers, Invensys Part No. 1190648.
4. Remove orifice **19** through bottom opening.

– To reassemble, replace parts in reverse sequence.

(On reassembly, be sure that **19a** is fully seated in its groove. Also, beveled edge of **19a** faces upward toward adapter **27**).

3" and 4" Model 121 Standard

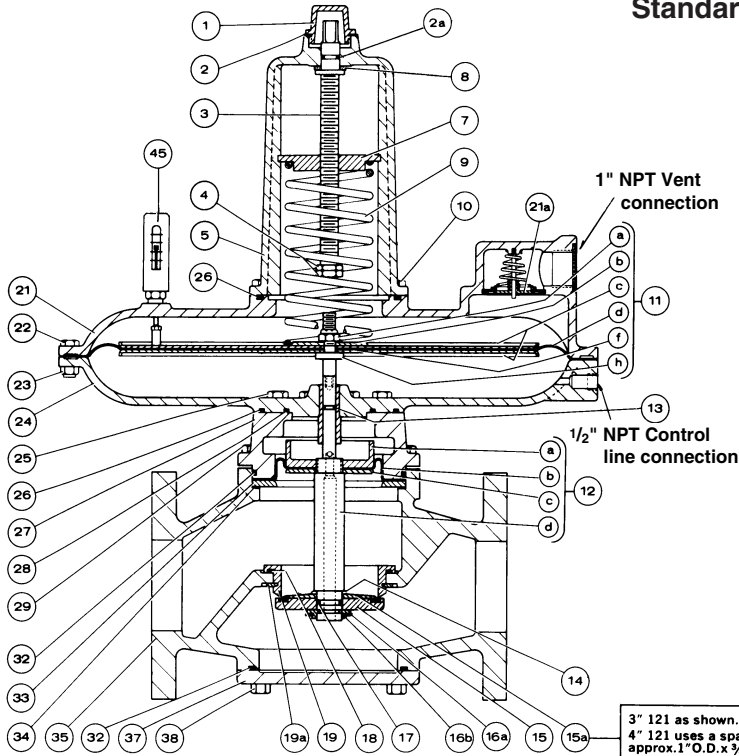

121-16

3" 121 as shown.
4" 121 uses a spacer,
approx. 1" O.D. x 3/4" I.D.
x 3/4" thick.

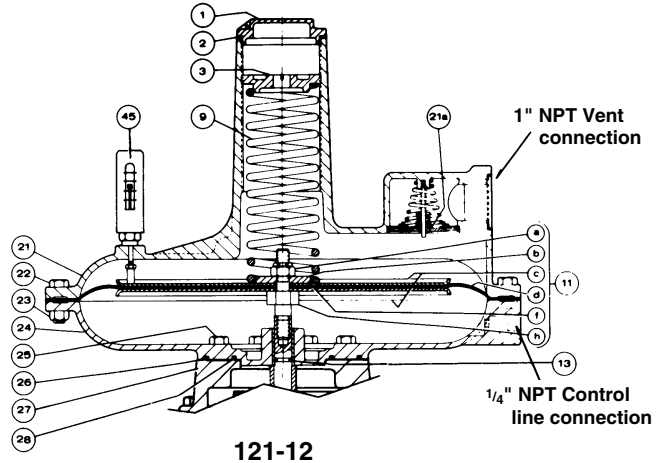

121-12

PIPE SIZES (inlet x outlet)	
3" x 3"	Flanged ANSI 125 lb. FF
4" x 4"	

3" and 4" Model 121 Back Pressure

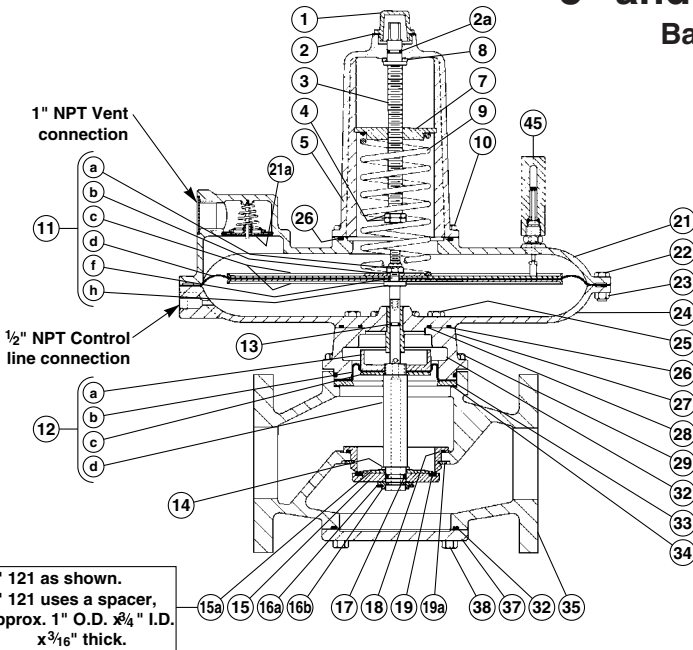

121-16

3" 121 as shown.
4" 121 uses a spacer,
approx. 1" O.D. x 3/4" I.D.
x 3/16" thick.

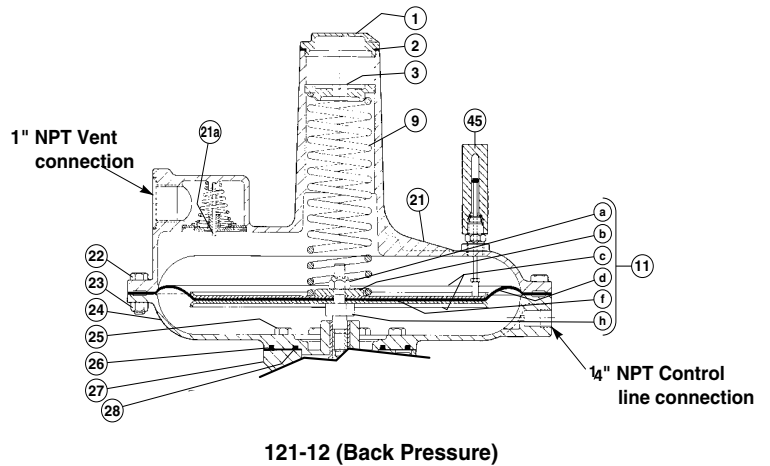

121-12 (Back Pressure)

Condensed Parts List 3" and 4"

ILL. NO.	DESCRIPTION	PART NUMBER	ILL. NO.	DESCRIPTION	PART NUMBER		
3" and 4" Model 121	1 Seal Cap for 121-16	138-02-005-01	3" Model 121 only	12 12a Piston	121-20-053-50		
	1 Seal Cap for 121-12	143-16-005-00		12b Seal Diaphragm, Buna-N	121-20-364-50		
	2 Seal Cap Gasket for 121-16	120-08-066-00		12b Seal Diaphragm, Viton	121-20-364-51		
	Tetraseal for 121-12, 2 1/4", x 2 3/8"	905241		12c Plate	121-20-010-50		
	3 Adjustment Spring Button for 121-12	143-16-009-00		12d Stem, stainless steel	121-20-016-51		
	8 Thrust Washer	141-10-160-01		15 Molded Valve, Buna-N (45-50 Duro)	121-20-311-50		
	9 Spring, see table "Spring Ranges"			Molded Valve, Viton-A (65-75 Duro)	121-20-311-51		
	11 121-16 Diaphragm Assembly			15a Valve Wing	121-20-018-50		
	11a Elastic Stop Nut 52-NTE-066	908561		Valve Wing, stainless steel	121-20-018-51		
	11b Bottom Spring Button	121-62-022-50		18 Tetraseal (or O-Ring) 3 3/4" x 4"	904200		
	11c Diaphragm Pan	121-62-017-50		19 Orifice, 3 1/4" dia., steel	121-20-023-50		
	11d Diaphragm, Buna-N	121-62-150-50		Orifice, 3 1/4" dia., stainless steel	121-20-023-51		
	11d Diaphragm, Viton	121-62-150-52		19a Retaining Ring, stainless	904658		
	11f Seal Washer	121-10-178-50		Pliers for retaining ring 19a, Truarc 0600	1190648		
	11h Diaphragm Stud, stainless steel	121-16-058-52		32 Tetraseal (or O-Ring) 5" x 5 1/4"	934328		
	11 121-12 Diaphragm Assembly (3 1/2" w.c. to 2 psi outlet pressure)	121-16-550-51		33 Seal Diaphragm Ring	121-20-008-50		
	11a Elastic Stop Nut 29-NE-066	903955		34 Gasket	121-20-104-50		
	11b Bottom Spring Button	121-10-022-50		45 Travel Indicator (specify scale 091-00-008-02)	091-00-365-00		
	11c Diaphragm Pan	121-16-017-50		FOR BACK PRESSURE MODELS			
	11d Molded Diaphragm, Buna-N	121-16-150-53		12 Item 12d above, Stem - substitute			
	11d Diaphragm, Viton	121-16-150-55		47 Stem, Back Pressure	121-20-016-53		
	11f Seal Washer	121-10-178-50		Add Item 47			
	11h Diaphragm Stud, stainless steel	121-16-058-52		Valve, Seal Diaphragm and Stem Assembly	121-20-511-50		
	13 O-Ring, Buna-N, 3/8" x 1/2"	934007		4" Model 121 only			
	O-Ring, Viton, 3/8" x 1/2"	902418					
	14 Wave Washer	905481					
	16a Retaining Ring	904448					
	Pliers for retaining ring 16a, Truarc 0400	1190647					
	16b Valve Holder, split (pair required), stainless steel	121-22-130-51					
	17 O-Ring, Buna-N, 5/8" x 3/4"	902922					
	O-Ring, Viton, 5/8" x 3/4"	902698					
	26 Tetraseal (or O-Ring) 4 3/8" x 4 5/8"	904085					
	28 Tetraseal (or O-Ring) 2 3/4" x 3"	904079					
	46 Repair Kits, consisting of Buna-N Main and Seal Diaphragm, Buna-N Molded Valve plus Wave Washer and Retaining Ring, Buna-N O-Rings, Tetraseals and Gaskets:						
	For 3" 121-16	121-60-598-50					
	3" 121-12	121-20-598-50					
	4" 121-16	121-62-598-50					
	4" 121-12	121-22-598-50					
	FOR BACK PRESSURE MODELS						
	14 Item 14 above, Wave Washer - substitute Poly-U Disk Retainer	121-22-102-52 121-22-103-50					

Servicing – General Instructions

Same general instructions as listed on Page 6.

To Service Valve (15)

1. Remove bolts **38** and remove bottom cap **37**.
 2. Remove retaining ring **16a**. Use Truarc 0400 pliers, Invensys Part No. 1190647.
 3. Remove both halves of valve holder **16b**.
 4. Remove valve **15**, and wing **15a** or spacer (wave washer **14** will probably also come off...do not lose it).
- To reassemble, replace parts in reverse sequence.

To Service Main Diaphragm (11d)

1. Remove top cap **1**.
 2. Release adjustment **3** (count the turns of adjustment **3** and use for returning the adjustment to this setting during reassembly).
 3. Remove bolts **10** and housing **5** (3" and 4" 121-16 only).
 4. Remove spring **9**.
 5. Remove bolts **22** and upper case **21**.
 6. Rotate diaphragm assembly **11** counterclockwise (this unscrews **11h** from **12d**) and remove.
 7. To disassemble diaphragm assembly, remove nut **11a**. Carefully note location and position of all parts to be certain of correct reassembly. Abrasive side of emery cloth washers face against diaphragm.
- To reassemble, replace parts in reverse sequence.

Make the screwed connection between 11h and 12d loose by approximately 1/2 turn. To do this, carefully rotate diaphragm assembly **11** clockwise until this screwed connection bottoms (do not jam it together). Then, back-off diaphragm assembly **11** counterclockwise approximately 1/2 turn...this is very important...the **11h** to **12d** screwed connection must not be tight.

To Service Orifice (19)

1. Remove valve **15** per section "To Service Valve (15)".
2. Remove seal diaphragm assembly **12** per step 2 under "To Service Seal Diaphragm (12b)".
3. Remove retaining ring **19a**. Use Truarc 0600 pliers, Invensys Part No. 1190648.
4. Remove ring **33** and orifice **19** through top opening.
 - To reassemble, replace parts in reverse sequence.

(On reassembly, be sure that **19a** is fully seated in its groove. Also, beveled edge of **19a** faces downward toward bottom cap **37**).

To Service Seal Diaphragm (12b)

1. Remove valve **15** per section "To Service Valve (15)".
 2. Remove bolts **29** and upper case assembly. Then remove seal diaphragm assembly **12**.
 3. To disassemble **12**, unscrew piston **12a** from stem **12d**. Use a spanner wrench in notch in skirt of piston (this can also be done by inserting a standard 7/32" Allen wrench in the notch).
- To reassemble, replace parts in reverse sequence.

Make certain that fabric side of seal diaphragm **12b** faces upward and "rubber" side faces downward toward body.

Do not pinch loop in seal diaphragm **12b** between ring **33** and centerpiece **27**. Also, rounded edge of **33** faces upward toward seal diaphragm **12b**.

Make the screwed connection between 11h and 12d loose by approximately 1/2 turn. To do this, carefully rotate seal diaphragm assembly **12** clockwise until this screwed connection bottoms (do not jam it together). Then, back-off seal diaphragm assembly **12** counterclockwise approximately 1/2 turn...this is very important...the **11h** to **12d** screwed connection must not be tight.

Servicing – Back Pressure Models General Instructions

Same general instructions as listed on Page 6.

To Service Valve (15)

1. Remove bolts **29** and remove upper case assembly and washer **33**.
 2. Remove retaining ring **16a**. Use Truarc 0400 pliers, Invensys Part No. 1190647.
 3. Remove both halves of valve holder **16b**.
 4. Remove valve **15** and wing **15a** or spacer (washer **14** and holder **14b** will probably also come off... do not lose them).
- To reassemble, replace parts in reverse sequence.

To Service Main Diaphragm (11d)

1. Remove top cap **1**.
 2. Release adjustment **3** (count the turns of adjustment **3** and use for returning the adjustment to this setting during reassembly).
 3. Remove bolts **10** and housing **5** (3" and 4" 121-16 only).
 4. Remove spring **9**.
 5. Remove bolts **22** and upper case **21**.
 6. Rotate diaphragm assembly **11** counterclockwise (this unscrews **11h** from **12d**) and remove.
 7. To disassemble diaphragm assembly, remove nut **11a**. Carefully note location and position of all parts to be certain of correct reassembly. Abrasive side of emery cloth washers face against diaphragm.
- To reassemble, replace parts in reverse sequence.

Make the screwed connection between 11h and 12d loose by approximately 1/2 turn. To do this, carefully rotate diaphragm assembly **11** clockwise until this screwed connection bottoms (do not jam it together). Then, back-off diaphragm assembly **11** counterclockwise approximately 1/2 turn... this is very important... the **11h** to **12d** screwed connection must not be tight.

To Service Orifice (19)

1. Remove valve **15** per section "To Service Valve (15)", item 1.
 2. Remove retaining ring **19a** and ring **33** through top opening. Use Truarc 0600 pliers, Invensys Part No. 1190648.
 3. Remove orifice **19** through bottom opening.
- To reassemble, replace parts in reverse sequence.
- (On reassembly, be sure that **19a** is fully seated in its groove. Also, beveled edge of **19a** faces downward toward bottom cap **37**.)

To Service Seal Diaphragm (12b)

1. Remove valve **15** per section "To Service Valve (15)", item 1.
 2. Remove bolts **29** and upper case assembly and then remove seal diaphragm assembly **12**.
 3. To disassemble **12**, unscrew piston **12a** from stem **12d**. Use a spanner wrench in notch in skirt of piston (this can also be done by inserting a standard 7/32" Allen wrench in the notch).
- To reassemble, replace parts in reverse sequence.

Make certain that fabric side of seal diaphragm **12b** faces upward and "rubber" side faces downward toward body.

Do not pinch loop in seal diaphragm **12b** between ring **33** and centerpiece **27**. Also, rounded edge of **33** faces upward toward seal diaphragm **12b**.

Make the screwed connection between 11h and 12d loose by approximately 1/2 turn. To do this, carefully rotate seal diaphragm assembly **12** clockwise until this screwed connection bottoms (do not jam it together). Then, back-off seal diaphragm assembly **12** counter-clockwise approximately 1/2 turn... this is very important... the **11h** to **12d** screwed connection must not be tight.

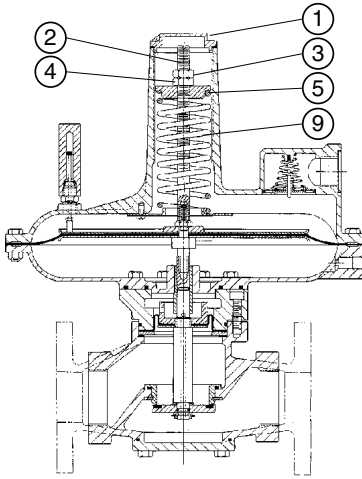

Vacuum Breaker

Vacuum Breakers are vacuum limiting devices. In their general function, they can be compared to relief valves or back pressure regulators.

The breaker outlet and control line are piped to the vacuum. The breaker inlet connects to a lesser vacuum, to atmosphere or to a positive pressure. The maximums for the positive pressure are 60 psi for 3/4" through 2 1/2" sizes, 40 psi for 3" and 15 psi for 4".

The vacuum breaker is normally closed and excess vacuum creates a valve opening movement which increases flow from the inlet and thereby relieves or "breaks" the excess.

All of the pipe sizes listed on Page 18 are available 3/4" through 4". Note on the cutaway drawing that the main spring is reversed to provide the upward closing force on the valve. Except for certain parts used in the spring assembly, everything else is interchangeable with standard 121 regulators.

Vacuums and Springs

SIZE	VACUUM RANGE "w.c. vacuum (-"w.c.)	SPRING COLOR	SPRING PART NUMBER
3/4", 1" and 1 1/4" 121-8	3" to 6 1/2"	Red-Black	143-82-021-00
	5" to 8 1/2"	Blue-Black	143-82-021-01
	8" to 14"	Green-Black	143-82-021-02
	12" to 20"	Blue (2" O.D.)	143-16-021-04
	18" to 30"	Green (2" O.D.)	143-16-021-05
	30" to 56"	Orange (2" O.D.)	143-16-021-06
1 1/2", 2" and 2 1/2" 121-12	3" to 6 1/2"	Red (2" O.D.)	143-16-021-03
	5" to 8 1/2"	Blue (2" O.D.)	143-16-021-04
	8" to 14"	Green (2" O.D.)	143-16-021-05
	12" to 28"	Orange (2" O.D.)	143-16-021-06
	28" to 56"	Black	143-16-021-07
3" and 4" 121-16	3" to 5 1/2"	Red (3" O.D.)	121-62-021-50
	4" to 7 1/2"	Blue (3" O.D.)	121-62-021-51
	7" to 14"	Green (3" O.D.)	121-62-021-52
3" and 4" 121-12	12" to 28"	Orange (2" O.D.)	143-16-021-06
	28" to 56"	Black	143-16-021-07

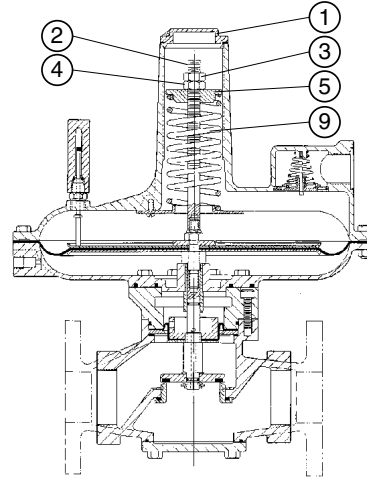

Vacuum Regulator

Vacuum Regulators are used to maintain a certain negative pressure (vacuum) in enclosed spaces such as tanks, vessels, chambers, piping system, etc. In general, these are piped to the regulator inlet and control line connections and the regulator outlet piped to the inlet of a vacuum pump or other vacuum source.

Available pipe sizes are 3/4" thru 2 1/2", as listed on Page 18. Note on the cutaway drawing that the spring assembly is arranged for an upward force on the valve. Also, the valve itself is normally open and moves downward to close rather than upward as in the standard 121. With the exception of certain parts involved in the foregoing, everything else is interchangeable with standard 121 regulators.

Vacuums and Springs

SIZE	VACUUM RANGE "w.c. vacuum (-"w.c.)	SPRING COLOR	SPRING PART NUMBER
3/4", 1" and 1 1/4" 121-8	3" to 6 1/2"	Red-Black	143-82-021-00
	5" to 8 1/2"	Blue-Black	143-82-021-01
	8" to 14"	Green-Black	143-82-021-02
	12" to 20"	Blue	143-16-021-04
	18" to 30"	Green	143-16-021-05
1 1/2", 2" and 2 1/2" 121-12	3 1/2" to 6 1/2"	Red	143-16-021-03
	5" to 8 1/2"	Blue	143-16-021-04
	8" to 14"	Green	143-16-021-05

To Service Vacuum Breaker or Vacuum Regulator:

- Remove cover cap 1. Measure depth from top of cover to ferrule (5) for reassembly.
- Hold stem (2) from turning using screwdriver on end of stem.
- Unlock nut (3) from nut (4) and remove nut (3).
- Slowly remove nut (4) maintaining pressure on spring ferrule (5) to prevent ejection of the spring from the upper case.

CAUTION: Do not allow stem (2) to unscrew during removal of nut (4).

- Remove spring 9.
- To service vacuum breaker, follow procedure for standard regulators by size.
- To service vacuum regulator, follow procedure for back pressure regulators by size.

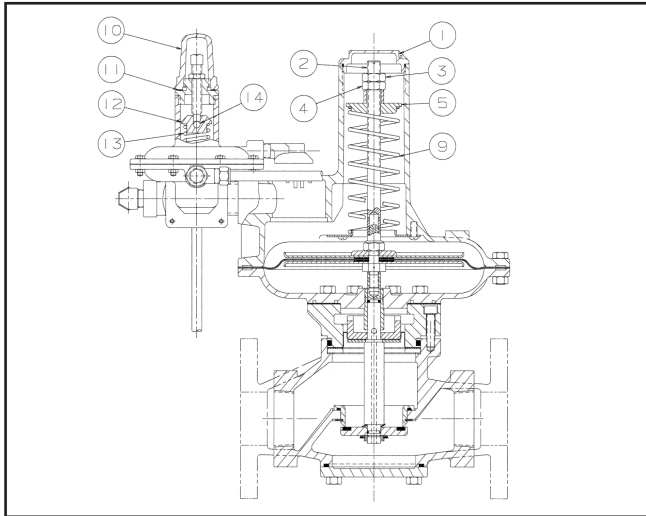

121-RPC (Relay Pilot Control)

The 121-RPC is a genuine **Pilot Operated Regulator** (Relay Principal of Operation). The relay principal means exceptional precise control. Accuracy is largely unaffected by changes in the inlet pressure.

The control line is piped to both the inlet and main regulator. The loading pressure to the main regulator varies with the downstream pressure resulting in precise regulation. Available in 1-1/2", 2" and 2-1/2" pipe sizes, the outlet pressure ranges from 3-1/2" w.c. through 35 psig. Note on the cutaway drawing that the main spring is reversed to provide the upward closing force.

OULET PRESSURE RANGE	PILOT SPRING	
	SPRING COLOR	SPRING PART NUMBER
3-1/2" to 6-1/2" w.c.	Red	143-08-021-00
5" to 8-1/2" w.c.	Blue	143-08-021-01
6" to 14" w.c.	Green	143-08-021-02
12" to 28" w.c.	Orange	143-08-021-03
1 psig to 2 psig	Black	143-08-021-06
1 psig to 5 psig	White	138-18-021-01
3 psig to 15 psig	Gray	138-18-021-04
10 psig to 35 psig	Brown	138-18-021-03
3-1/2" w.c to 5 psig	Aluminum	138-18-021-05

SET-POINT ADJUSTMENT

The 121-RPC is factory-adjusted as specified on the order. To change the set-point:

1. Remove pilot seal cap (10) and loosen lock nut (12).

CAUTION: Do not remove main cover cap (1). It is sealed and pressured and does not contribute to set-point adjustment.

2. Turn set-point adjustment (11) clockwise to increase or counter clockwise to decrease the outlet pressure.

CAUTION: There should be gas flow through the regulator during adjustment, preferable small (approximately 250 SCFH). Do not adjust set-point when there is no flow.

3. When the desired set-point is achieved, retighten lock-nut (12) and install seal cap (10). Make sure tetraseal (13), is not damaged.

PILOT SPRING CHANGE

The outlet pressure range of the 121-RPC is determined by the pilot spring (see table of Outlet Pressure Ranges). To change the spring:

1. Take regulator out of service per the following section "Shut-Down".

NOTE: Do not change main spring (9). It does not contribute to set-point adjustment.
2. Remove pilot seal cap (10), loosen lock-nut (12), and turn set-point adjustment (11) counter clockwise until spring compression is released.
3. Remove top cap (14), ferrule (15), and spring (17). Be careful to not loose ball (16).
4. Install new spring. During reassembly make sure the spring is nested correctly at both ends.
5. Adjust to the desired set-point per previous section "Set-Point Adjustment".

TO SERVICE 121-RPC

1. Remove cover cap (1). Measure depth from top of cover to ferrule (5) for reassembly.
2. Hold stem (2) from turning using screwdriver on end of stem.
3. Unlock nut (3) from nut (4) and remove nut (3).
4. Slowly remove nut (4) maintaining pressure on the spring ferrule (5) to prevent ejection of the spring from the upper case.

CAUTION: Do not allow stem (2) to unscrew during removal of nut (4).
5. Remove spring (9).
6. At pilot, disconnect control line which connects to downstream piping.
7. Disconnect pilot supply line between body and pilot regulator.
8. Follow procedures for standard 121 regulators by size.

Maximum Emergency Pressures

The maximum inlet pressures Model 121 bodies that may be subjected to under abnormal conditions without causing internal damage are as follows:

- 1. 1" through 2 1/2" pipe size 70 psi
- 3" pipe size 50 psi
- 4" pipe size 25 psi

The maximum pressures the diaphragms in Model 121 regulators that may be subjected to under abnormal conditions without causing internal damage are as follows:

- 1. Model 121-8 set-point plus 5 psi
- Model 121-8HP set-point plus 10 psi
- Model 121-12 set-point plus 5 psi
- Model 121-16 set-point plus 2 psi

Set-point is defined as the outlet pressure a regulator is adjusted to deliver.

If any of the above limits are exceeded the regulator must be taken out of service and inspected. Damaged or otherwise unsatisfactory parts must be repaired or replaced before returning the regulator to service.

The maximum pressures that can be safely contained by Model 121 diaphragm cases are as follows:

- Model 121-8 25 psi
- Model 121-8HP 25 psi
- Model 121-12 20 psi
- Model 121-16 10 psi

Safely contained means no leakage as well as no bursting.

Before using any of the above data, make sure this entire section is clearly understood.

Dimensions

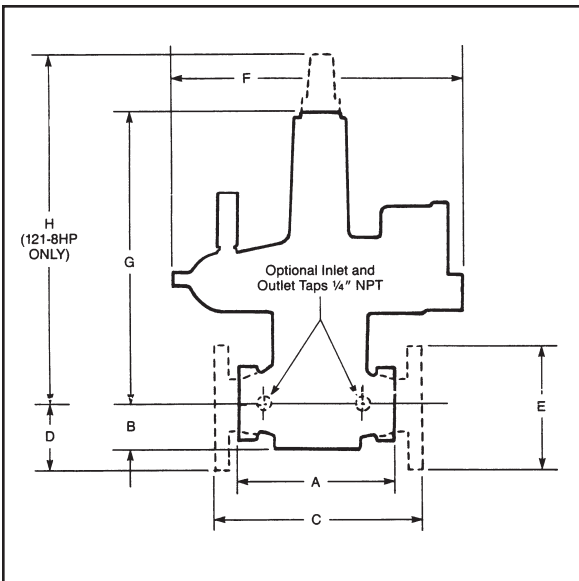

Full Open Capacity

Capacity of the Model 121 in the wide-open position can be calculated using the following formulas:

$$1. Q = K \sqrt{P_0(P_1 - P_0)}$$

$$2. Q = \frac{K P_1}{2}$$

Q = maximum capacity of the regulator (in SCFH of 0.6 specific gravity natural gas).

K = the "K" factor, the regulator constant (from bottom of table, Page 5).

P₁ = absolute inlet pressure (psia).

P₀ = absolute outlet pressure (psia).

Use formula 1. when $\frac{P_1}{P_0}$ is less than 1.894.

Use formula 2. when $\frac{P_1}{P_0}$ is greater than 1.894.

3. K Factors =

- 1" Pipe Size (outlet) K = 1400
- 1 1/4" Pipe Size (outlet) K = 1750
- 1 1/2" Pipe Size K = 2750
- 2" Pipe Size K = 4750
- 2 1/2" Pipe Size K = 5250
- 3" Pipe Size K = 11000
- 4" Pipe Size K = 18000

Capacity is calculated using the following formula and K factors:

Remember, at the above full open capacities the droop is significantly greater than specified in the capacity tables.

When checking 121 regulator capacity to provide adequate relief

PIPE SIZE	MODEL NUMBER	SCREWED NPT		FLANGED ANSI 125 LB. FF			F (dia.)	G	HIGH PRESSURE SPRING ADJUSTMENT
		A	B	C	D	E			
3/4" - 1" - 1 1/4"	121-8 & -8HP	5 3/4	1 7/8	-	-	-	10 3/16	13 9/16	19 1/8
1 1/2"	121-8 & -8HP	7 1/2	2 3/8	-	-	-	10 3/16	13 3/16	19 1/4
1 1/2"	121-12	7 1/2	2 3/8	-	-	-	14	14 1/8	-
2"	121-8 & -8HP	7 1/2	2 3/8	10	3	6	10 3/16	13 11/16	19 1/4
2"	121-12	7 1/2	2 3/8	10	3	6	14	14 1/8	-
2 1/2"	121-8 & -8HP	8 1/4	2 3/8	-	-	-	10 3/16	13 11/16	19 1/4
2 1/2"	121-12	8 1/4	2 3/8	-	-	-	14	14 1/8	-
3"	121-12	11 3/4	3 9/16	11 3/4	3 3/4	7 1/2	14	15 5/8	-
3"	121-16	11 3/4	3 9/16	11 3/4	3 3/4	7 1/2	18	19	-
4"	121-12	-	-	13 7/8	4 1/2	9	14	16 1/2	-
4"	121-16	-	-	13 7/8	4 1/2	9	18	20	-

Overpressurization Protection

Protect the downstream piping system and the regulator's low pressure chambers against overpressurization due to the possible regulator malfunction or failure to achieve complete lockup. The allowable outlet pressure is the lowest of the maximum pressures permitted by federal codes, state codes, Equimeter Bulletin RDS-1498 or other applicable standards. The method of protection can be a relief valve, monitor regulator, shutoff device or similar mechanism.

Materials of Construction

Body and Adapter	Cast Iron
Diaphragm Case (8" and 12" Diaphragm)	Die Cast Aluminum Alloy
Diaphragm Case (16" Diaphragm)	Permanent Mold Aluminum Alloy
Main and Seal Diaphragms	Buna-N on Nylon
Piston for Seal Diaphragm (3/4" thru 2 1/2" Model 121)	Powdered Iron-Zinc Plated
Piston for Seal Diaphragm (3" and 4" Model 121)	Aluminum Alloy
Stem, Stud, Pans and Plates for 8", 12" and 16" Diaphragms	Plated Steel
Stem Bushing	Stainless Steel
Orifice (3/4" thru 1 1/4" Model 121)	Brass
Orifice (1 1/2" thru 4" Model 121)	Cast Iron
Retaining Ring (1 1/2" thru 4" Model 121)	Plated Steel
Valve	Plated Steel with Molded Buna-N Soft Seat
Valve Wing (3" Model 121)	Plated Steel
Valve Holder	Plated Steel
Retaining Ring and Wave Washer	Stainless Steel
O-Rings and Tetraseals	Buna-N
Adjustment Spring Ferrule	Zinc Die Casting
Bottom Spring Button	Powdered Iron-Plated
Adjustment Screw (16" Diaphragm) and H.P. Adjustment Spring Screw	Plated Steel
Adjustment Ferrule (16" Diaphragm) and H.P. Adjustment Spring Ferrule	Cast Iron
Seal Cap (8" and 12" Diaphragm)	Zinc Die Casting
Seal Cap (16" Diaphragm)	Die Cast Aluminum Alloy

Body Taps

Inlet and outlet taps are available on either side of the body. Tap size is 1/4" NPT. Refer to "dimensions" on Page 18. Desired taps must be specified when ordering.

Other Gases

Model 121 Regulators are most widely used on natural gas. However, they perform equally well on LP gas, nitrogen, dry CO₂, air and others.

OTHER GASES	CORRECTION FACTOR
Air (Specific Gravity 1.0)	0.77
Propane (Specific Gravity 1.53)	0.63
1350 BTU Propane-Air Mix (1.20)	0.71
Nitrogen (Specific Gravity 0.97)	0.79
Dry Carbon Dioxide (Specific Gravity 1.52)	0.63
For other noncorrosive gases: CORRECTION FACTOR =	$\sqrt{\frac{0.60}{\text{Specific gravity of the gas}}}$

**Sensus Metering Systems, 805 Liberty Boulevard
DuBois, PA 15801
(814) 371-8000
FAX (814) 375-8460
www.sensus.com**

Representatives in all principal cities.
Distributors throughout the world.



Sensus Metering Systems
805 Liberty Boulevard
DuBois, PA 15801
www.sensus.com

Authorized Distributor:

LIMITED WARRANTY Seller warrants the Goods to be free from defects in materials manufactured by Seller and in Seller's workmanship for a period of **[one (1) year]** after tender of delivery (the "Warranty Period"). **THIS LIMITED WARRANTY (a) IS IN LIEU OF, AND SELLER DISCLAIMS AND EXCLUDES, ALL OTHER WARRANTIES, STATUTORY, EXPRESS OR IMPLIED, INCLUDING, WITHOUT LIMITATION, ANY WARRANTY OF MERCHANTABILITY OR FITNESS FOR A PARTICULAR PURPOSE, OR OF CONFORMITY TO MODELS OR SAMPLES; (b)** does not apply to any Goods which have been (i) repaired, altered or improperly installed; (ii) subjected to improper use or storage; (iii) used or incorporated with other materials or equipment, after Buyer or anyone using the Goods has, or reasonably should have, knowledge of any defect or nonconformance of the Goods; or (iv) manufactured, fabricated or assembled by anyone other than Seller; **(c)** shall not be effective unless Buyer notifies Seller in writing of any purported defect or nonconformance within **[thirty (30) days]** after Buyer discovers or should have reasonably discovered such purported defect or nonconformance; and **(d)** shall only extend to Buyer and not to any subsequent buyers or users of the Goods. Buyer shall provide Seller access to the Goods as to which Buyer claims a purported defect or nonconformance; upon request by Seller, Buyer shall, at its own risk and expense, promptly return the Goods in question to Seller's Plant.