



A BTR Company

# T-10 HP Turbo-Meters With Slot Sensor Pulser On Follower Magnet Assembly

## Description

The Slot Sensor Pulser provides a high frequency electrical pulse signal which is directly proportional to the T-10 HP Turbo-Meter's mechanical output. Easily retrofitted to existing T-10 HP Turbo-Meters or factory installed in new meters, the pulser signals can be used to actuate a wide variety of remotely located electronic volume totalization or rate of flow devices.

The attached drawings, MM-1625-B5 and B6 (on Pages 6 and 7) detail data for pulses per unit of volume and pulse output frequency for each size of T-10 HP Turbo-Meter.

The signal is generated from a slotted chopper disc mounted on the meter's follower magnet assembly. When the meter is operating, this disc rotates in the slot of an inductive proximity sensor which detects the presence or absence of metal.

Wiring from the sensor exits the meter instrument mounting housing through a 1/2" — 14 NPT standard conduit fitting or a three pin plug-in connector. To preserve the integrity of the intrinsically safe electrical system, wiring must be connected to either the specified safety barrier or the specified intrinsically safe transistor output module. Both of these accessory devices must be located in a safe (i.e. non-hazardous) area in accordance with the attached copies of connection diagrams MM-1588-1, MM-1571-7 or MM-1643. Note that diagram MM-1588-1 is applicable when remote instruments manufactured by Equimeter are used. Connection diagrams MM-1571-7 and MM-1643 must be followed when connecting non-Equimeter instrumentation.

## Retrofit Capability

Slot sensor retrofit kits can be field installed on any Equimeter T-10 HP Turbo-Meters.

As will be noted in the retrofit kit installation instructions which follow, the components involved are installed in the non-pressurized instrument mounting housing. Therefore, meter blow-down is not necessary while making a retrofit kit installation.

## Retrofit Kits

Slot Sensor Pulser Retrofit Kit components are the same for all meter working pressure ratings. Therefore, all T-10 HP Turbo-Meters use the same Retrofit Kit, regardless of the meter pressure rating.

Retrofit Kit Part Numbers are as follows:

Turbo-Meter Size and Model	Retrofit Kit Part Numbers	
	Conduit	Bendix (Plug-in)
2" or 3" T-10 HP	006-19-633-01	006-19-633-00

NOTE: When ordering T-10 HP Turbo-Meter Slot Sensor Pulser Retrofit Kits, be sure to also order either a safety barrier or a transistor output control amplifier module, as appropriate. Refer to drawings MM-1588-1, MM1571-7 or MM-1643 (Pages 5, 10 and 11).

## Retrofit Kit Components

Item*	Part Numbers	Part Description
1	006-24-313-22	Follower magnet/17 slot chopper disc assembly for all meters
2	006-24-319-03	Slot sensor/bracket assembly
3	903373	#8-32 x 1/2" lg. machine screw
4	950371	#8-L washer
5A	006-20-330-01	1/2"—14 NPT conduit/wire adapter for all sizes of Turbo-Meters
5B	006-20-319-01	Bendix (plug-in)
6	800646	Shrink Tubing
7	950661	Gasket
8	903025	#4-40 x 1/4" lg. S.S. Rd. Hd. screw
9	006-32-331-01	Cap and chain
10	950124	Female connector Bendix (plug-in)
11	006-19-107-01	Instrument Housing
11A	006-24-505-01	Vent

\* Refer to call-out number on drawings M-1625-B2 (page 9) for conduit assembly and M-1625-B1 (page 8) for Bendix Assembly.

### New Meters—Factory Installation:

New T-10 H.P. Turbo-Meters can, of course, be ordered with the Slot Sensor Pulsar factory installed. Just specify this option when new meter orders are placed, and again be sure to also specify either the safety barrier or transistor output module, drawings MM-1588-1, MM-1571-7.

## Retrofit Kit Installation Instructions

Refer to drawing M-1625-B1 (Page 9).

### Disassembly

- A. Remove instrument, and/or index box cover, index plate (Item 14) and index.
- B. Remove intermediate gear train (Item 12). NOTE: Retain all the above items for reassembly later.
- C. Remove existing follower magnet and discard (Item 13).
- D. Remove existing instrument housing (Item 11) and discard. NOTE: Save four cap screws 15 for reassembly later.

### Reassembly

(Refer to drawing M-1625-B2 for conduit connector, drawing M-1625-B1 for plug-in connector.)

- A. Install the new instrument housing 11 onto the body employing the four screws 15.
- B. Place the new follower/magnet chopper assembly 1 onto the magnet well post.
- C. Reassemble intermediate gear train 12 in instrument housing 11. Use only two of the three retaining screws 3 in the two holes furthest from the connector mounting hole.
- D. Insert lockwasher 4 and mounting screw 3 into sensor bracket 2.
- E. Hold the sensor bracket by the thumb tap 2B and place it down into the instrument housing.  
  
NOTE: While lowering the sensor bracket into place, rotate the switch and wires away from the chopper disc and gears. Then tighten screw 3 to hold the sensor bracket assembly in place (prior to adjustment).

**For Conduit Connector:** Drawing M-1625-B2 (Page 9).

Insert the wire connector end of the 1/2 NPT conduit wire adapter 5A through gasket 7 and the connector hole in the instrument housing 11 and secure with the flange screws 8.

**For Plug-in Connector:** Drawing M-1625-B1 (Page 8).

Insert the wires of the connector 5B through the gasket 7 and the connector hole in the instrument housing 11 and install one of the screws 8 through chain ring 9A. Orient connector key at 12 o'clock position and secure with flange screws 8.

Slide a piece of shrink tubing 6 over each of the wires from slot sensor 2C. Solder wires from slot sensor 2C to wires from connector 5A or 5B (red to red, black to black). Slide shrink tubing 6 over each soldered joint and heat shrink tubing over joints. Route wires away from moving parts.

Contact your Equimeter representative for details on M-1625-B9 for Continuation of Instructions (Adjustment and Final Installation).

## Adjustment

Refer to drawing M-1625-B2 for conduit connector, drawing M-1625-B1 for plug-in connector.)

- A. Loosen sensor bracket retaining screw 3—this will allow the sensor assembly to pivot by holding tab 2B.
- B. Loosen locking screw 2D and adjust the vertical position of sensor switch by turning adjustment screw 2E to position the chopper disc in the center of the opening in the slot sensor 2C.

CW—will raise the switch

CCW—will lower the switch

C. Pivot the sensor assembly until the chopper disc extends into the switch slot approximately  $\frac{3}{16}$ ". This can be accomplished by pivoting the sensor assembly until the chopper disc contacts the back of the switch slot, then back off the sensor assembly to provide approximately  $\frac{1}{16}$ " clearance.

D. Hold the sensor assembly in position while tightening the pivot locking screw 3.

E. Check vertical adjustment of switch for clearance by rotating the chopper disc a complete revolution. Make final adjustment with screw 2E and lock in position by tightening screw 2D.

NOTE: If possible, before reassembling the index plate and index and/or instrument, complete the wiring per MM-1588-1 or MM-1571-7. Verify the adjustment of the sensor switch through the electrical operation.

NOTE: It is also recommended that the switch slot and chopper disc clearance be checked while the meter is running.

**T-10 HP Turbo-Meters  
With Slot Sensor Pulsar  
on Follower Magnet Assembly**

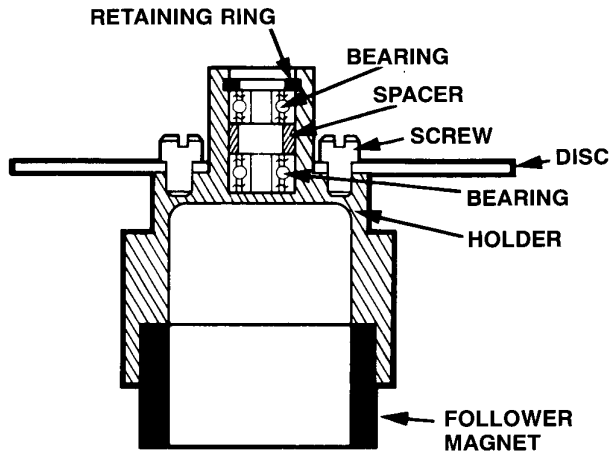

**Follower Magnet and Bearing Assembly  
with Chopper Disc (X section, side view)**

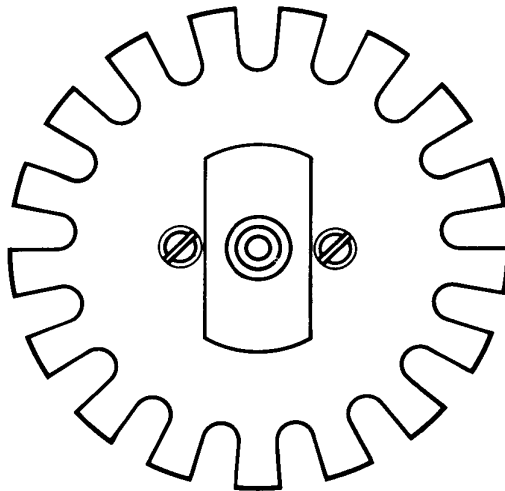

**Follower Magnet and Bearing Assembly  
with 17 slot Chopper Disc (top view)**

**MM-1643**

**CONNECTION DIAGRAM FOR MARK II, T-10 AND TPL-9 TURBO-METERS OR VDR INDEX with SLOT SENSOR PULSER using NON-EQUIMETER INSTRUMENTATION (24 VDC SUPPLY) (For connection through certified Pepperl and Fuchs Control Amplifier Type KG30-T30/Ex)**

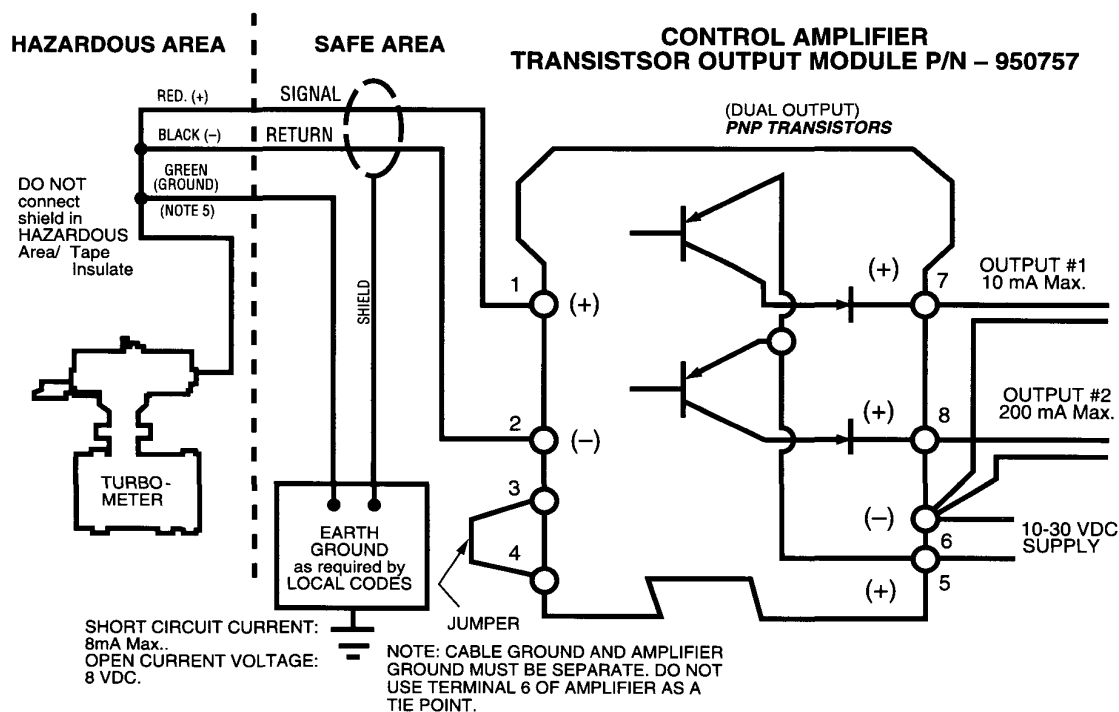

**Control Amplifier Enclosure MTL-UC2, Part No. 950583**

CONTROL AMPLIFIER MUST BE INSTALLED ACCORDING TO MANUFACTURER'S INSTRUCTIONS, AND MUST COMPLY WITH APPLICABLE LOCAL CODES IN A MANNER APPROVED BY THE AUTHORITY HAVING JURISDICTION. REFER TO INSTALLATION INSTRUCTIONS PACKAGED WITH CONTROL AMPLIFIER.

1. ALL SIGNAL WIRES CONNECTING THE SLOT SENSOR TO THE CONTROL AND AMPLIFIER MUST BE RUN SEPARATELY FROM ALL OTHER WIRING. THIS IS NECESSARY TO COMPLY WITH INTRINSIC SAFETY GUIDELINES.
2. USE 2 CONDUCTOR #18 TWISTED SHIELDED CABLE BELDEN 8760 OR EQUIVALENT. FOR MAXIMUM PROTECTION, CONDUIT IS RECOMMENDED.
3. MAXIMUM CABLE LENGTH FROM METER TO CONTROL AMPLIFIER MUST BE LESS THAN 1000 FT.
4. MODULE IS P.F. CONTROL AMPLIFIER KG30-T30/Ex PART NUMBER 950757.
5. IF METER IS ISOLATED, CONNECT WIRE TO EARTH GROUND. IF METER IS NOT ISOLATED, DO NOT CONNECT GREEN WIRE TO GROUND.

OPTIONAL: CONTROL AMPLIFIER ENCLOSURE MTL-2, PART NO. 950583

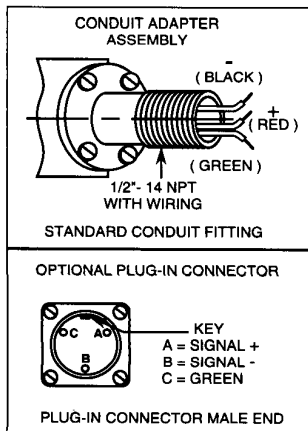

**CAUTION**

This diagram illustrates a possible connection arrangement for interfacing MARK II, T-10 and TPL-9 Turbo-Meter slot-sensor pulser (NAMUR-type inductive proximity sensor) with nominal 24 VDC powered, Non-Equimeter instrumentation. Determine compatibility of amplifier outputs with your input requirements BEFORE making final connections and PLEASE note the following additional cautions:

1. PNP output transistors are NOT Potential-free.
2. Emitter of BOTH transistors is connected INTERNALLY to POSITIVE (+) DC supply line.
3. Improperly connected outputs could DAMAGE amplifier or customer equipment.

..... NOT approved for use in Canada .....



A BTR Company

MM-1625-B6

## 2" T-10 H.P. TURBO-METER WITH SLOT SENSOR PULSER ON FOLLOWER MAGNET

### PULSES PER UNIT VOLUME AND PULSE OUTPUT FREQUENCY TABLE

STANDARD CONSTRUCTION				SPECIAL CONSTRUCTION					
CHOPPER DISC SLOTS MAX. CAPACITY (ACFH) MECHANICAL OUTPUT INTER. GEAR RATIO		17 SLOTS 10000 ACFH 100 Ft.3/Rev. 122.0555 to 1 ENGLISH		17 SLOTS 283 m3/H 1 m3/Rev 43.10526 TO 1 METRIC		17 SLOTS 10000 ACFH 10 Ft.3/Rev. 12.1125 TO 1 ENGLISH		17 SLOTS 283 m3/H 10 m3/Rev 431.0526 METRIC	
CHANGE GEARS LG.	SM.	P/Ft.3	Hz	p/m3	Hz	p/Ft.3	Hz	p/m3	Hz
74 -74	T/47 -47	32.669	90.748	1153.754	90.698	32.420	90.056	1153.754	90.698
74 -76	T/47 -48	32.853	91.259	1160.250	91.209	32.603	90.563	1160.250	91.209
74 -73	T/47 -46	32.928	91.468	1162.905	91.417	32.677	90.771	1162.905	91.417
74 -75	T/47 -47	33.111	91.974	1169.345	91.924	32.858	91.273	1169.345	91.924
74 -77	T/47 -48	33.286	92.460	1175.516	92.409	33.032	91.755	1175.516	92.409
74 -74	T/47 -46	33.380	92.721	1178.835	92.670	33.125	92.014	1178.835	92.670
*74 -76	T/47 -47	33.552	93.201	1184.936	93.149	33.296	92.490	1184.936	93.149
74 -73	T/47 -45	33.660	93.501	1188.747	93.449	33.404	92.788	1188.747	93.449
74 -75	T/47 -46	33.831	93.974	1194.765	93.922	33.573	93.257	1194.765	93.922
74 -77	T/47 -47	33.994	94.427	1200.527	94.375	33.735	93.707	1200.527	94.375
74 -74	T/47 -45	34.121	94.781	1205.032	94.729	33.861	94.059	1205.032	94.729
74 -76	T/47 -46	34.282	95.227	1210.696	95.174	34.020	94.501	1210.696	95.174
74 -73	T/47 -44	34.425	95.626	1215.764	95.573	34.163	94.897	1215.764	95.573

**\*BASE CHANGE GEAR SET**

EXAMPLE: (with BASE change gear set)

$$p/Ft3 = \frac{(\text{intermediate gear ratio}) \times (\text{number teeth large change gear}) \times (\text{number disc slots})}{(\text{mechanical output}) \times (\text{number teeth small change gear})}$$

$$p/Ft3 = \frac{122.0555 \times 76 \times 17}{100 \times 47} = \frac{157695.78}{4700} = 33.552 \text{ pulses/cubic foot}$$

$$Hz = \frac{p/Ft3 \times \text{maximum capacity}}{3600} = \frac{33.552 \times 10000}{3600}$$

Hz = 93.201 pulses per second at maximum flow rate



A BTR Company

MM-1625-B5

### 3" T-10 H.P. TURBO-METER WITH SLOT SENSOR PULSER ON FOLLOWER MAGNET

#### PULSES PER UNIT VOLUME AND PULSE OUTPUT FREQUENCY TABLE

STANDARD CONSTRUCTION				SPECIAL CONSTRUCTION				
CHOPPER DISC SLOTS MAX. CAPACITY (ACFH) MECHANICAL OUTPUT INTER. GEAR RATIO	17 SLOTS 10000 ACFH 100 Ft.3/Rev. 122.0555 to 1 ENGLISH		17 SLOTS 283 m3/H 1 m3/Rev 43.10526 TO 1 METRIC		17 SLOTS 10000 ACFH 10 Ft.3/Rev. 12.1125 TO 1 ENGLISH		17 SLOTS 283 m3/H 10 m3/Rev 431.0526 METRIC	
	CHANGE GEARS LG. SM.	P/Ft.3	Hz	p/m3	Hz	p/Ft.3	Hz	p/m3
71 -73 T/50 -50 T	30.294	84.151	1069.873	84.104	30.063	83.509	1069.873	84.104
71 -72 T/50 -49 T	30.489	84.692	1076.752	84.645	30.257	84.046	1076.752	84.645
71 -71 T/50 -48 T	30.692	85.255	1083.918	85.208	30.458	84.605	1083.918	85.208
71 -74 T/50 -50 T	30.709	85.303	1084.528	85.256	30.475	84.653	1084.528	85.256
71 -73 T/50 -49 T	30.912	85.868	1091.707	85.820	30.677	85.213	1091.707	85.820
*71 -72 T/50 -48 T	31.124	86.456	1099.184	86.408	30.887	85.797	1099.184	86.408
71 -74 T/50 -49 T	31.336	87.044	1106.662	86.996	31.097	86.381	1106.662	86.996
74 -74 T/47 -49 T	31.336	87.044	1106.662	86.996	31.097	86.381	1106.662	86.996
71 -73 T/50 -48 T	31.556	87.657	1114.451	87.608	31.316	86.988	1114.451	87.608
74 -73 T/47 -48 T	31.556	87.657	1114.451	87.608	31.316	86.988	1114.451	87.608
74 -75 T/47 -49 T	31.759	88.220	1121.617	88.172	31.517	87.548	1121.617	88.172
74 -72 T/47 -47 T	31.786	88.296	1122.571	88.247	31.544	87.622	1122.571	88.247

**\*BASE CHANGE GEAR SET**

EXAMPLE: (with BASE change gear set)

$$p/Ft^3 = \frac{(\text{intermediate gear ratio}) \times (\text{number teeth large change gear}) \times (\text{number disc slots})}{(\text{mechanical output}) \times (\text{number teeth small change gear})}$$

$$p/Ft^3 = \frac{122.0555 \times 72 \times 17}{100 \times 48} = \frac{149396.00}{4800} = 31.124 \text{ pulses/cubic foot}$$

$$Hz = \frac{p/Ft^3 \times \text{maximum capacity}}{3600} = \frac{31.124 \times 10000}{3600}$$

Hz = 86.456 pulses per second at maximum flow rate

**T-10 HP TURBO-METER SLOT SENSOR PULSER FIELD INSTALLATION KIT**

M-1625-B1

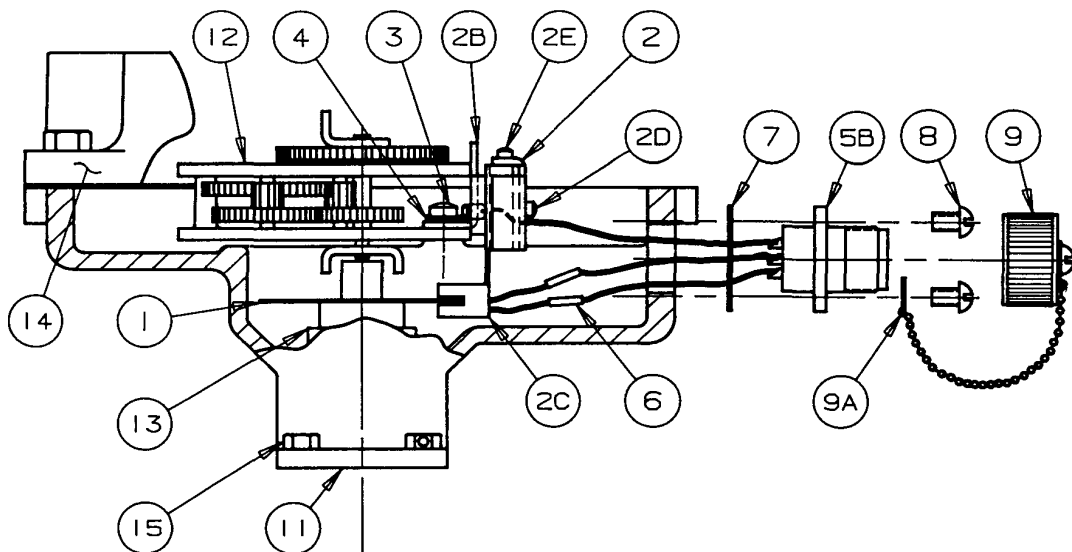
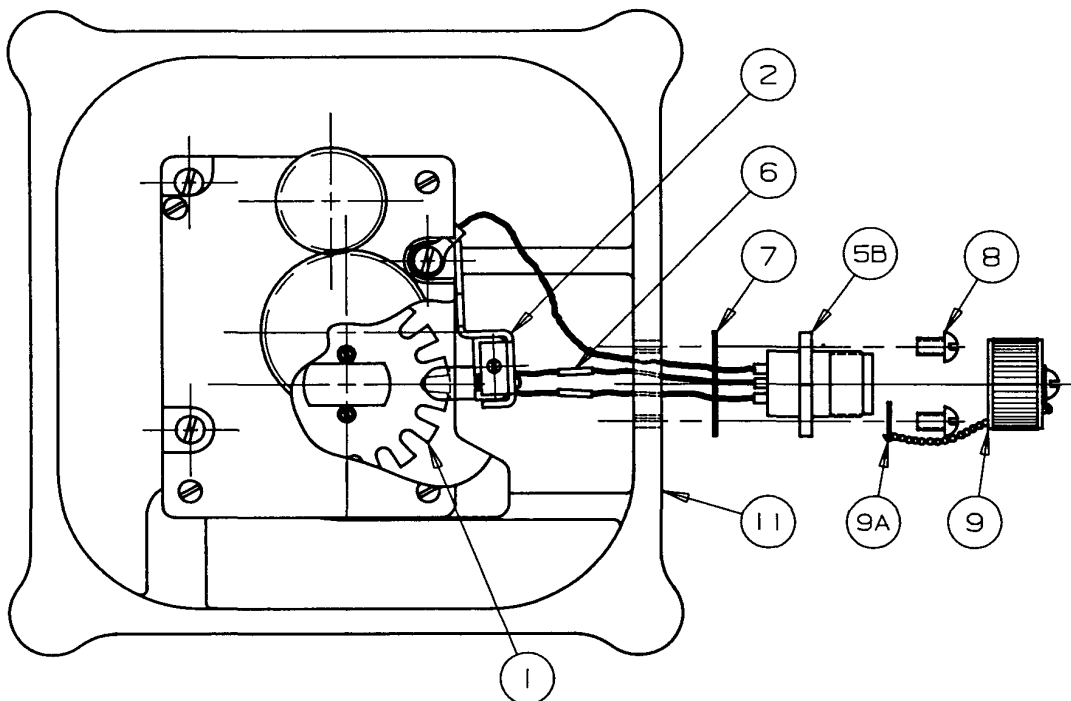



**T-10 HP TURBO-METER SLOT SENSOR PULSER FIELD INSTALLATION KIT**

M-1625-B2

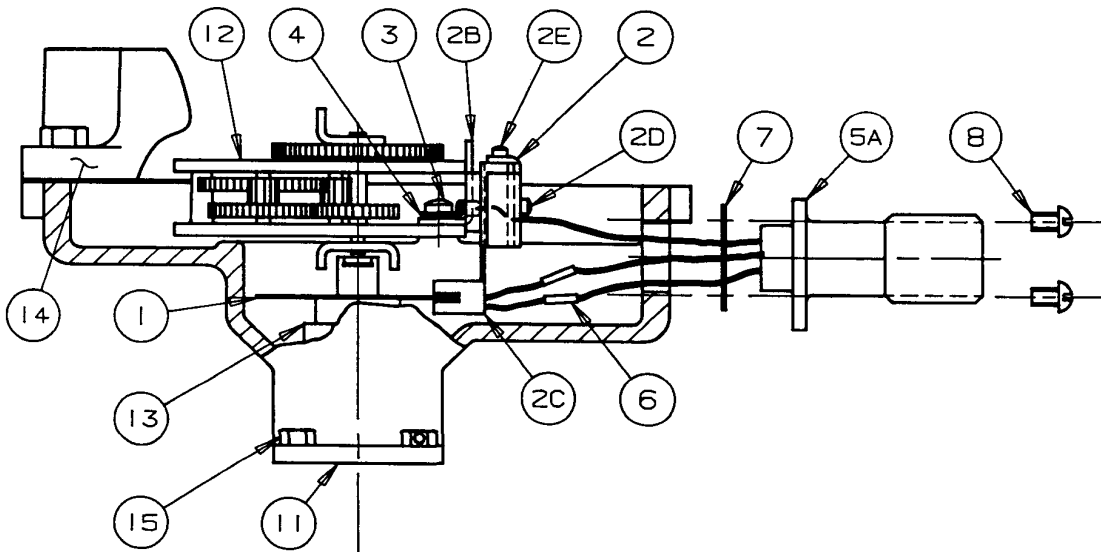
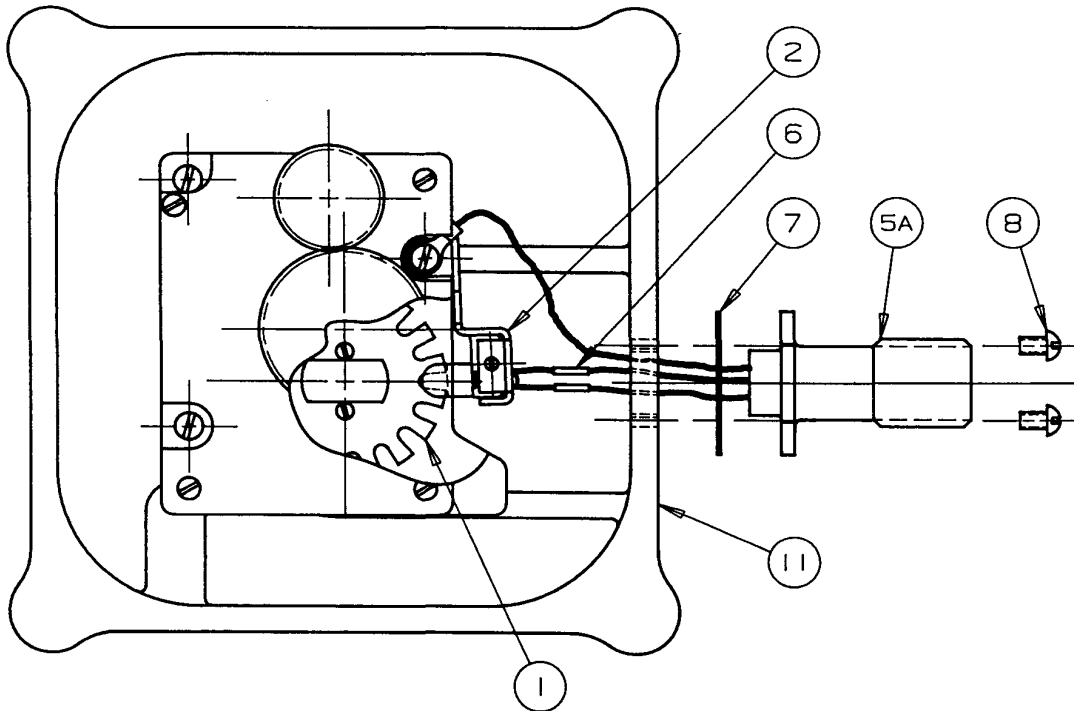

**MM-1588 -1**

**CONNECTION DIAGRAM FOR MARK II, T-10 AND TPL-9 TURBO - METERS OR VDR INDEX with SLOT SENSOR PULSER and EQUIMETER INSTRUMENTATION.**

(For connection through certified Zener Barrier device rated 30V or less 90 OHM or more.)

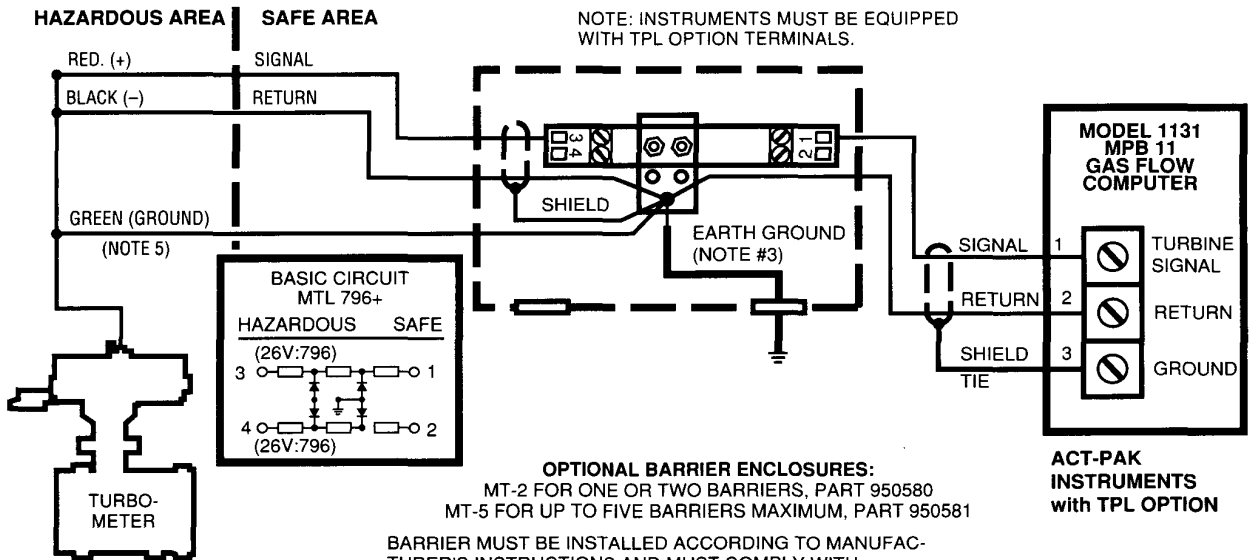

**OPTIONAL BARRIER ENCLOSURES:**  
 MT-2 FOR ONE OR TWO BARRIERS, PART 950580  
 MT-5 FOR UP TO FIVE BARRIERS MAXIMUM, PART 950581

BARRIER MUST BE INSTALLED ACCORDING TO MANUFACTURER'S INSTRUCTIONS AND MUST COMPLY WITH APPLICABLE LOCAL CODES IN A MANNER APPROVED BY THE AUTHORITY HAVING JURISDICTION, REFER TO INSTALLATION INSTRUCTIONS PACKAGED WITH BARRIER.

1. ALL SIGNAL WIRES CONNECTING THE SLOT SENSOR TO THE SHUNT DIODE SAFETY BARRIERS MUST BE RUN SEPARATELY FROM ALL OTHER WIRING. THIS IS NECESSARY TO COMPLY WITH INTRINSIC SAFETY GUIDELINES.
2. USE 2 CONDUCTOR #18 TWISTED SHIELDED CABLE BELDEN 8760 OR EQUIVALENT. FOR MAXIMUM PROTECTION, CONDUIT IS RECOMMENDED.
3. GROUND BUS IS CONNECTED TO EARTH GROUND BY AN INSULATED #12 WIRE, OR LARGER IF REQUIRED BY LOCAL CODES. RESISTANCE TO GROUND MUST BE LESS THAN ONE OHM. LOCAL CODES MAY REQUIRE REDUNDANT GROUND WIRES (TWO PLACES).
4. MAXIMUM CABLE LENGTH OF 1000 FEET RECOMMENDED.
5. WIRING SYSTEM SHOWN IS APPLICABLE FOR USE WITH EQUIMETER MPB-II FLOW COMPUTER OR EQUIMETER ACT-PAK INSTRUMENT ONLY. DO NOT USE THIS DIAGRAM FOR SYSTEMS INCORPORATING INSTRUMENTS NOT MADE BY EQUIMETER INCORPORATED.
6. SEE WIRING DIAGRAM ON EQUIMETER ACT-PAK INSTRUMENTS FOR DETAIL ON TERMINAL CONNECTIONS.
7. IF METER IS ISOLATED, CONNECT GREEN GROUND WIRE TO EARTH GROUND AT SAFETY BARRIER. IF METER IS NOT ISOLATED, DO NOT CONNECT GREEN WIRE TO GROUND.
8. INTRINSIC SAFETY CONDITIONAL UPON APPLICATION OF THE CERTIFIED SAFETY BARRIER WITH RATING OF 30V OR LESS, 90 OHMS OR MORE.

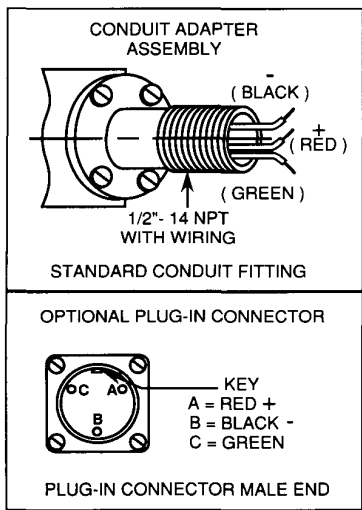
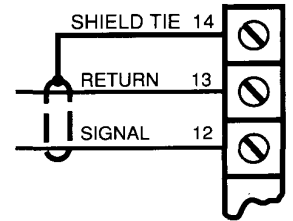

MM-1571-7

## CONNECTION DIAGRAM FOR EQUIMETER MARK II, T-10 AND TPL-9 TURBO-METERS OR VDR INDEX with SLOT SENSOR PULSER and NON-EQUIMETER INSTRUMENTATION.

(For connection through certified Pepperl and Fuchs Control Amplifier Type WE 77 / Ex1-0T)

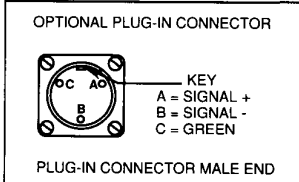
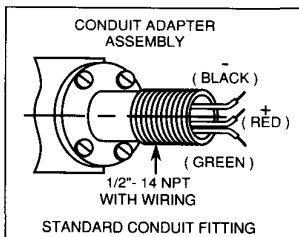
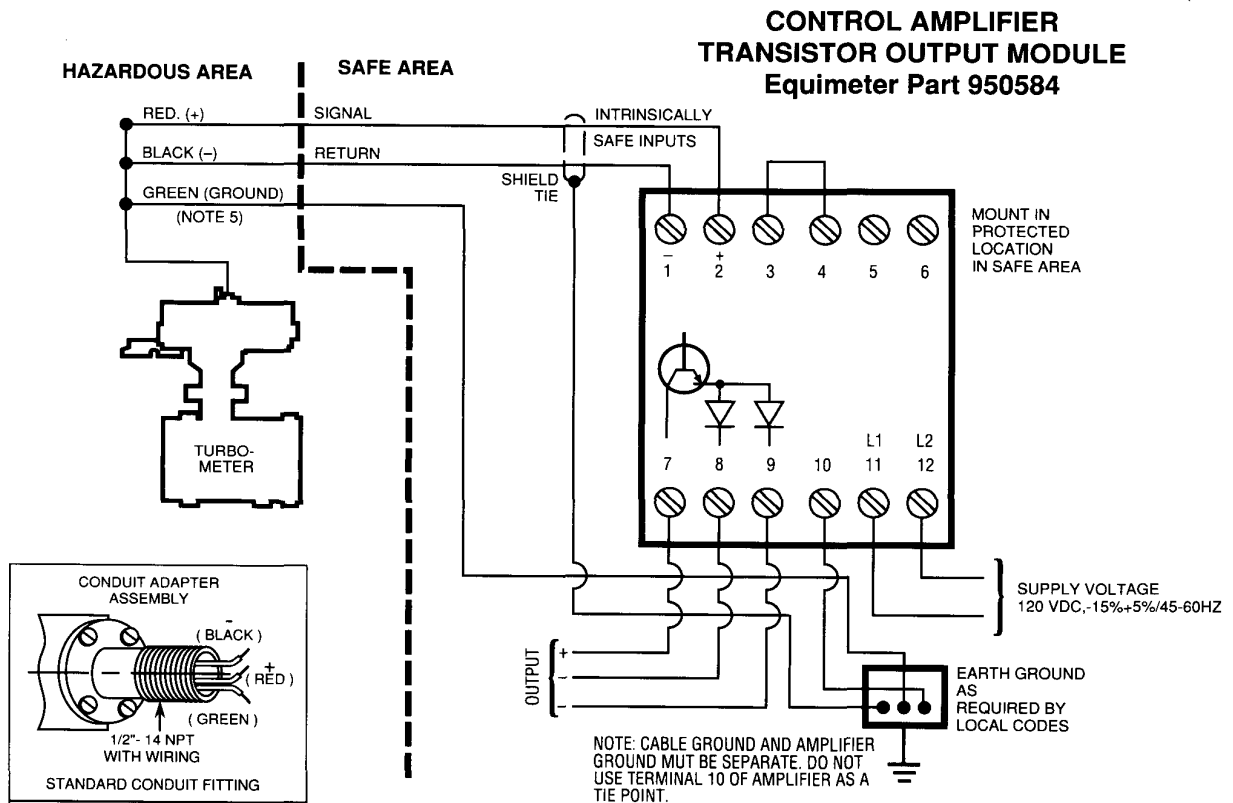

### Transistor Output

1 potential free transistor output with 2 decoupling diodes Galvanically isolated by optocoupler

Transistor max. Load  $U = 30V = 10mA$  short circuit proof, output limited to 10mA

Voltage drop 3V

Max. switching frequency

A mode 1kHz (with 1mA Load)

### Control Amplifier Enclosure MTL-UC2, Part No. 950583

CONTROL AMPLIFIER MUST BE INSTALLED ACCORDING TO MANUFACTURER'S INSTRUCTIONS, AND MUST COMPLY WITH APPLICABLE LOCAL CODES IN A MANNER APPROVED BY THE AUTHORITY HAVING JURISDICTION. REFER TO INSTALLATION INSTRUCTIONS PACKAGED WITH CONTROL AMPLIFIER.

1. ALL SIGNAL WIRES CONNECTING THE SLOT SENSOR TO THE CONTROL AMPLIFIER MUST BE RUN SEPARATELY FROM ALL OTHER WIRING. THIS IS NECESSARY TO COMPLY WITH INTRINSIC SAFETY GUIDELINES.
2. USE 2 CONDUCTOR #18 TWISTED SHIELDED CABLE BELDEN 8760 OR EQUIVALENT. FOR MAXIMUM PROTECTION, CONDUIT IS RECOMMENDED.
3. MAXIMUM CABLE LENGTH FROM METER TO CONTROL AMPLIFIER MUST BE LESS THAN 1000 FEET.
4. MODULE IS P.F. CONTROL AMPLIFIER WE77/EX1-0T EQUIMETER PART 950584.
5. IF METER IS ISOLATED, CONNECT WIRE TO EARTH GROUND. IF METER IS NOT ISOLATED, DO NOT CONNECT GREEN WIRE TO GROUND.

OPTIONAL: CONTROL AMPLIFIER ENCLOSURE MTL-UC2 PART #950583

**INTRINSIC SAFETY CONDITIONAL UPON APPLICATION OF CERTIFIED PEPPERL AND FUCHS AMPLIFIER WE77/EX1-0T.**

**PLEASE REFER TO DRAWING MM-1588-1 WHEN CONNECTING TO EQUIMETER INSTRUMENTS.**

---

**Equimeter Incorporated, 805 Liberty Boulevard, DuBois, PA 15801  
(814) 371-8000**

Representatives in all principal cities.  
Distributors throughout the world.



Equimeter Incorporated  
805 Liberty Boulevard  
DuBois, PA 15801

**A BTR Company**

---

**Authorized Distributor:**

**WARRANTY** Equimeter Incorporated (Equimeter) warrants its products only against defects in materials and workmanship. Equimeter's liability and customer's exclusive remedy under this warranty or any warranty extends for a period of one (1) year from the date of Equimeter's shipment and is expressly limited to repayment of the purchase price, repair, or replacement, at Equimeter's option, during said period, upon proof satisfactory to Equimeter and upon customer's returning and repaying all charges on such products to factory or warehouse designated by Equimeter. THIS WARRANTY IS MADE EXPRESSLY IN LIEU OF ALL OTHER WARRANTIES, EXPRESS, IMPLIED, OR STATUTORY, WITH RESPECT TO QUALITY, MERCHANTABILITY, OR FITNESS FOR A PARTICULAR PURPOSE.